

GSM Phase 2+

General Packet Radio Service GPRS: Architecture, Protocols, and Air Interface¹

Christian Bettstetter, Hans-Jörg Vögel, Jörg Eberspächer

: (http://www.mfamily.pe.kr)

: 2000 8 25

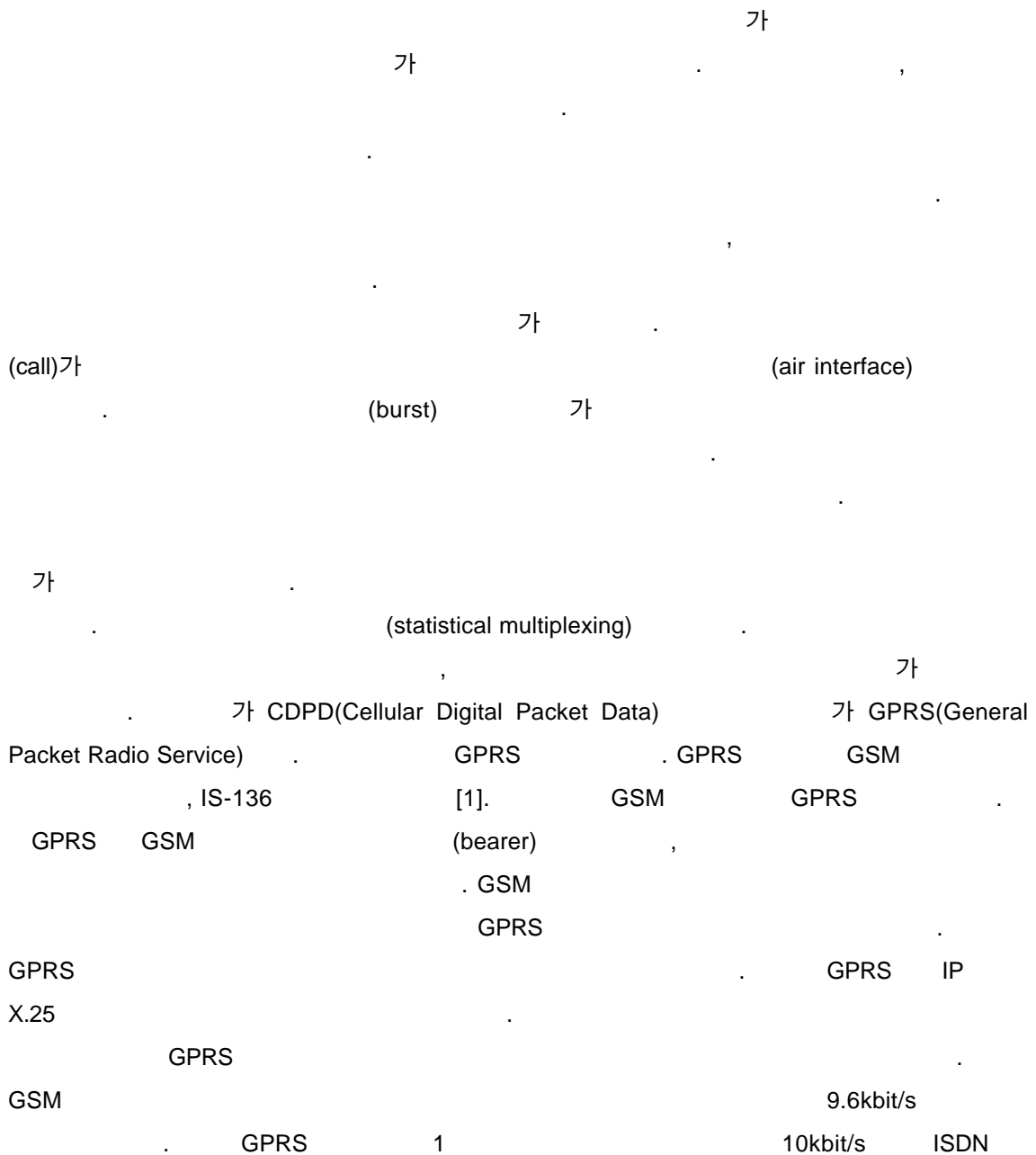

¹ IEEE Communications Survey, vol. 2, no. 3, 1999.

(100kbps)
 , GPRS
 (billing)
 , GPRS
 GPRS 5 ETSI(European Telecommunications Standards Institute)
 가 GSM
 가 , 2000 GPRS 가
 [2][3].
 가 GPRS
 [4] GSM
 GSM [5][6][7]. GPRS
 QoS
 . GPRS
 , GPRS
 , (multiple
 access),
 . GPRS , GPRS
 , GPRS

System Architecture

General GSM Concept

GPRS , GSM GSM
 (addressing) [5].
GSM System Architecture – 1 GSM PLMN(Public Land Mobile Network)
 [5]. MS(Mobile Station) GSM
 . BTS(Base Transceiver Station)가
 . BTS BSC(Base Station Controller) . BTS BSC
 BSS(Base Station Subsystem)
 MSC(Mobile Switching Center) . (ISDN

) 가 GSM MSC LA(Location Area) LA BSC 가

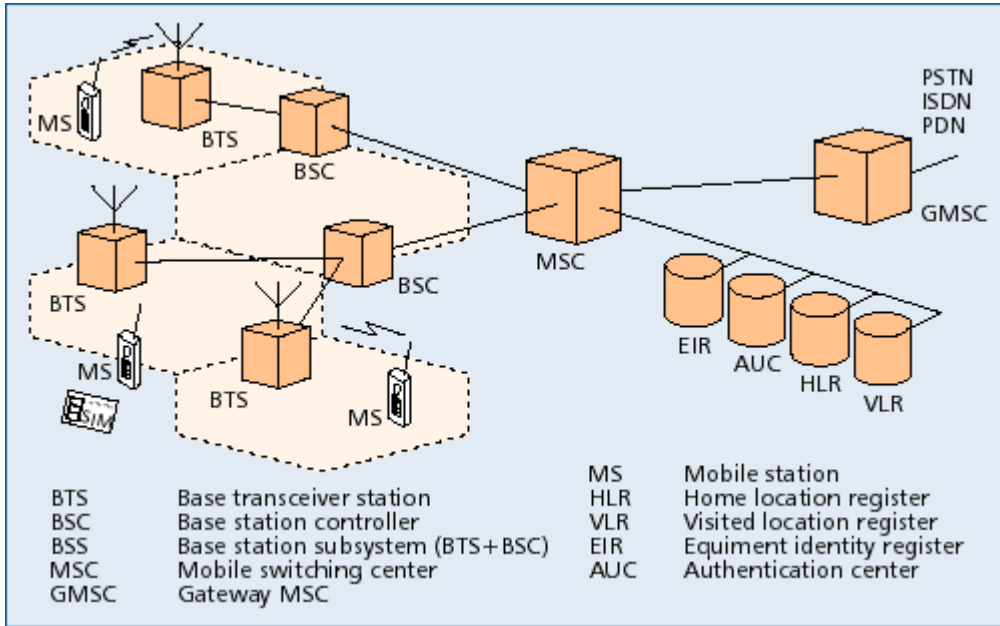

1. GSM

가 HLR(Home Location Register), VLR(Visited Location Register), AUC(Authentication Center), EIR(Equipment Identity Register)

HLR 가 (subscriber) (profile) () 가 HLR VLR LA HLR VLR ID 가 AUC AUC 가 가 , EIR

GSM Addresses and Identifiers – GSM

가 ID, ID ID가 ID (mobility management)

IMEI(International Mobile Equipment Identity)
IMEI 가 EIR 가
가 IMSI(International Mobile Subscriber Identity)
SIM(Subscriber Identity Module) (1)
IMSI SIM 가 IMEI 가
가
MSISDN(Mobile Subscriber ISDN Number)
SIM . SIM MSISDN
VLR ID
TMSI(Temporary Mobile Subscriber Identity) . TMSI VLR
LA HLR

GPRS System Architecture

GPRS GSM , GSN(GPRS Support Node)
가 [8]. GSN (PDN:
Packet Data Network) 2
GPRS
SGSN(Serving GPRS Support Node)
. SGSN
², (attach, detach, (location management)),
가
(, VLR), (IMSI, PDN) SGSN
GGSN(Gateway GPRS Support Node) GPRS (backbone) ³
. SGSN GGSN
PDP(Packet Data Protocol)
. GGSN PDP GSM
. SGSN
GGSN SGSN
. SGSN GGSN
² (routing)
(transfer) 가
³ GPRS 가

SGSN GGSN (many-to-many) 가 .
 GGSN SGSN
 SGSN
 GGSN
 2 ETSI , GSM GPRS 가
 [8].

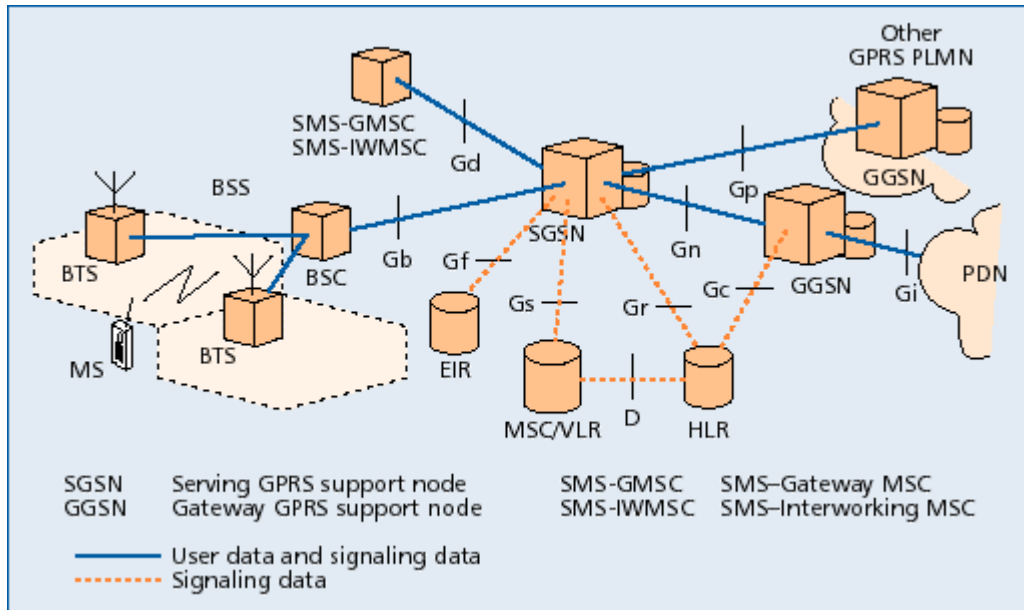

2. GPRS

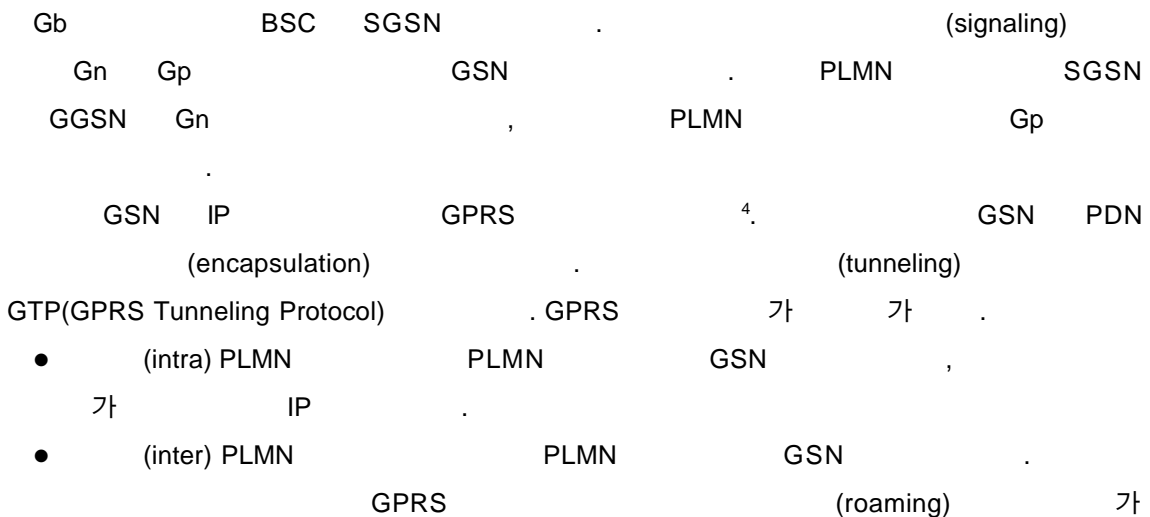

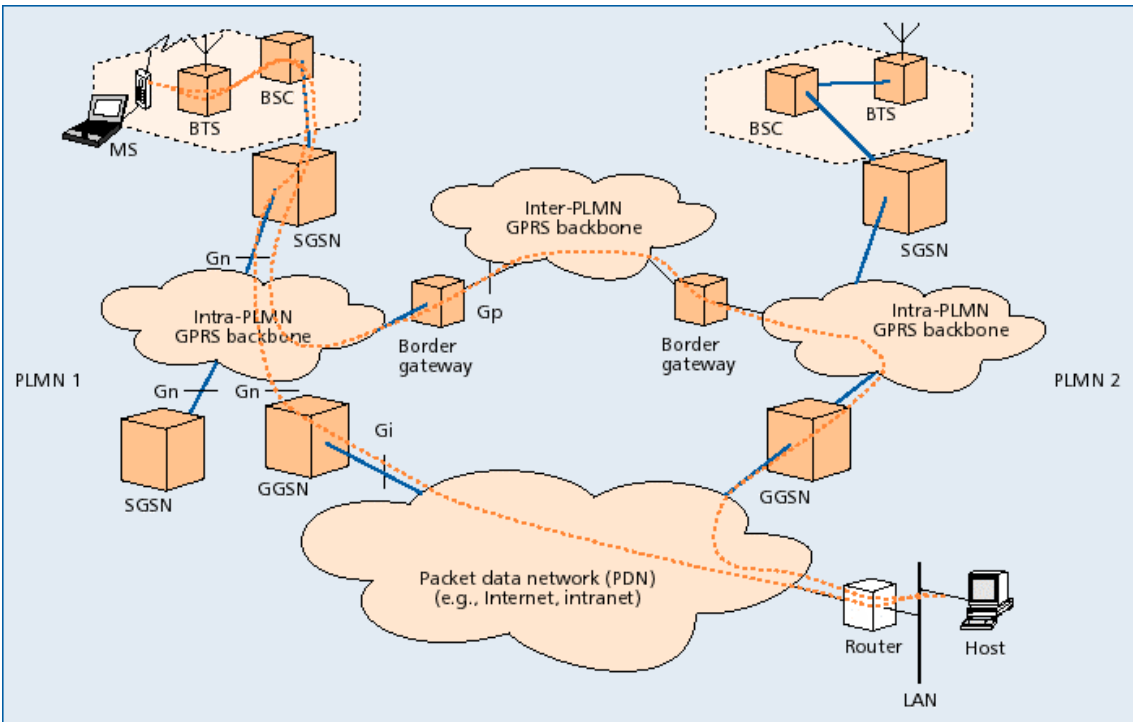
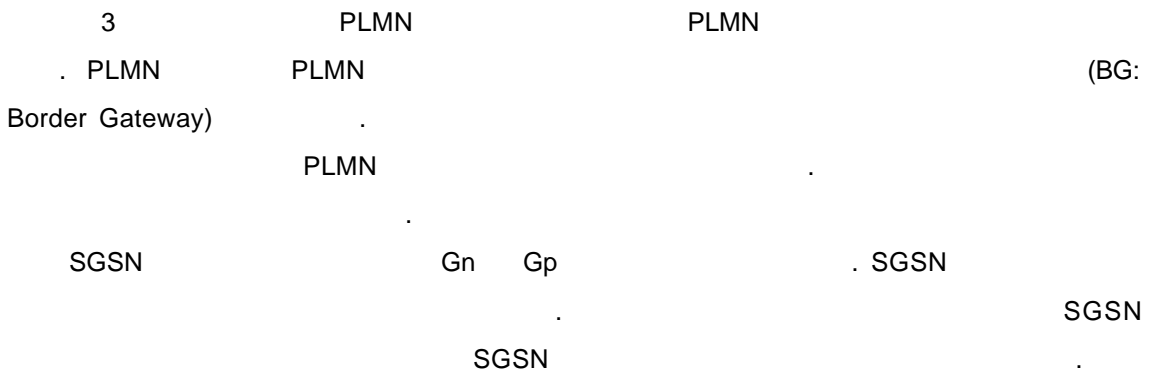

3. GPRS

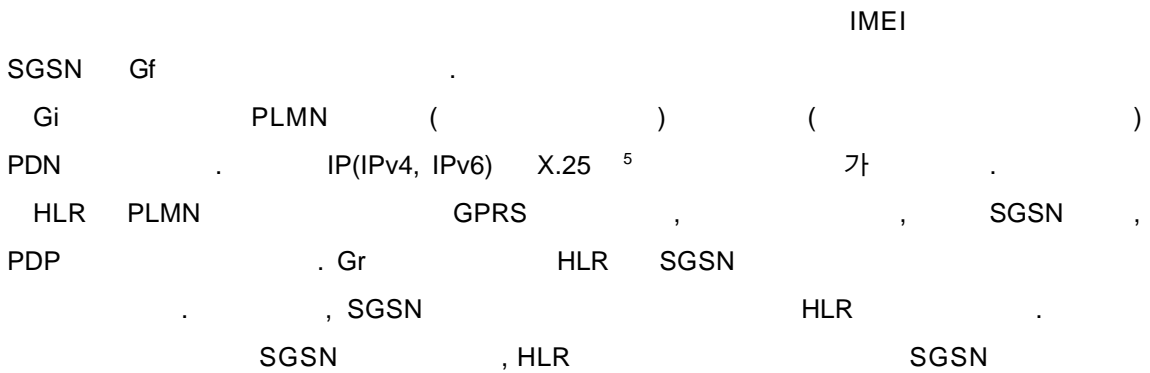

⁵ X.25

X.25

. GGSN HLR (Gc) GGSN

MSC/VLR GSM GPRS

, attach 가

, GSM (paging) SGSN . Gs

SGSN MSC/VLR

GPRS SMS(Short Message Service) Gd 가

SMS-GMSC SGSN

Services

Bearer Services and Supplementary Services

GPRS - -

- (PTP: Point-To-Point) - - (PTM: Point-To-Multipoint) 가 - -

PTP [9].

(PTP-CLNS: PTP connectionless network service) (PTP-CONS: PTP connection-oriented network service) IP

, X.25

PTM

[10]. 가 PTM 가

- (PTM-M): IP
- (PTM-G): ()

(master – slave)

SMS GPRS 가

CFU(Call Forwarding Unconditional), CFNRc(Call Forwarding on mobile subscriber Not Reachable), CUG(Closed User Group)

GPRS 가

[9].

Quality of Service

가 (session) QoS ()
 . GPRS 가 QoS
 [9].

- (service precedence)
 , , (high, normal, low) 가 .
- (reliability) . 3
 , , , ,
 (1 .)
- 95% (95%)
 (2 .)
 Gi
 . GPRS

GPRS
 GPRS

- (throughput)

1	10^{-9}	10^{-9}	10^{-9}	10^{-9}
2	10^{-4}	10^{-5}	10^{-5}	10^{-6}
3	10^{-2}	10^{-5}	10^{-5}	10^{-2}

1.

	128byte		1024byte	
		95%		95%
1	< 0.5s	< 1.5s	< 2s	< 7s
2	< 5s	< 25s	< 15s	< 75s
3	< 50s	< 250s	< 75s	< 375s
4	Best effort	Best effort	Best effort	Best effort

2.

QoS 가 ,
 QoS 가 . 가
 .
 QoS

Simultaneous Usage of Packet Switched and Circuit Switched Services

- (, , SMS) GRPS GSM/GPRS
 3 가 [9].
- A : GPRS GSM 가
 - B : GPRS GSM ,
 - C : GPRS GSM 가 ,

Session Management, Mobility Management, and Routing

GPRS ,

Attachment and Detachment Procedure

GPRS 가 GPRS 가 SGSN , HLR
 가 SGSN P-
 TMSI(Packet Temporary Mobile Subscriber Identity) GRPS attach
 IMSI attach
 GPRS attach . GPRS attach GPRS
 GPRS detach ,
 (SGSN HLR)

Session Management, PDP Context

GPRS attach , PDN(Packet Data Network)
 PDN IP

IP PDP(Packet Data Protocol) 가
PDP (context)가 , 가
PDP (IPv4),
PDP (129.187.222.10), QoS , PDN
GGSN , SGSN, GGSN . PDP
가 (activation) , PDN 가
가 . GGSN PDP IMSI
PDN . PDP
PDP 가
PLMN 6
가 가 PDP (static) .
PDP 가 PDP (dynamic)
PLMN 가 , 가
가 PLMN 가 .
가 . PDP 가 , PDP /
GGSN .

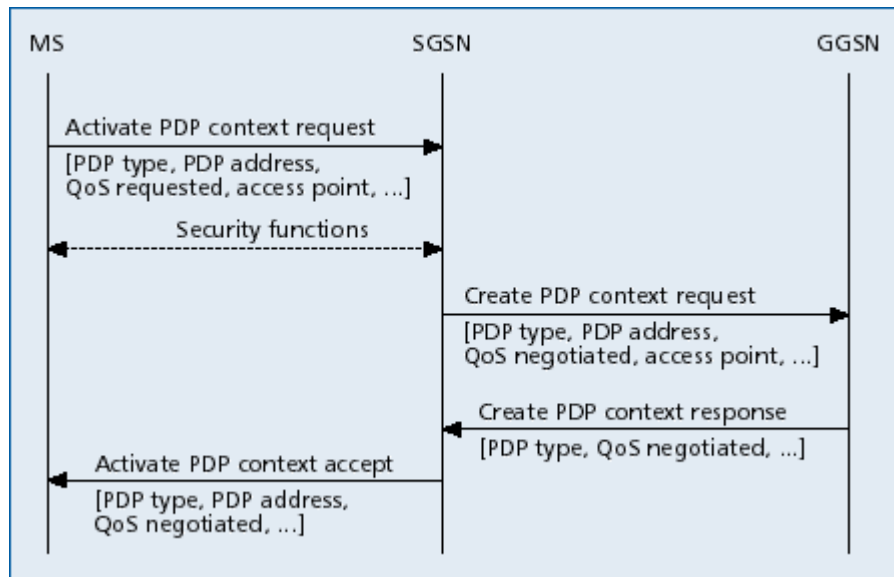

4. PDP

4 PDP “activate PDP context request” SGSN PDP 7
6 가 가
7 가 (SGSN) QoS 가 ,

PDP . PDP .
 가 , SGSN GGSN
 "create PDP context request" . GGSN PDP
 (entry) 가 . GGSN SGSN
 PDN . GGSN
 "create PDP context response" SGSN . PDP
 PDP 가 . SGSN PDP
 PDP 가 "activate PDP
 context accept"
 GPRS (anonymous) PDP . , 4
 , PDP 가
 가
 PDP .

Routing

3 GPRS .
 IP 가 . PLMN1 GPRS IP
 . SGSN
 , PDP GGSN . GGSN
 , IP . IP
 IP
 .
 PLMN PLMN2 가 . IP
 PLMN2 GGSN . IP 가 GGSN
 prefix 가 . 가
 가 . IP PLMN2 GGSN . GGSN
 HLR PLMN1 . GGSN
 PLMN1 SGSN . SGSN

Location Management

SGSN .

(downlink)

(uplink)

5 GPRS

[11].

가

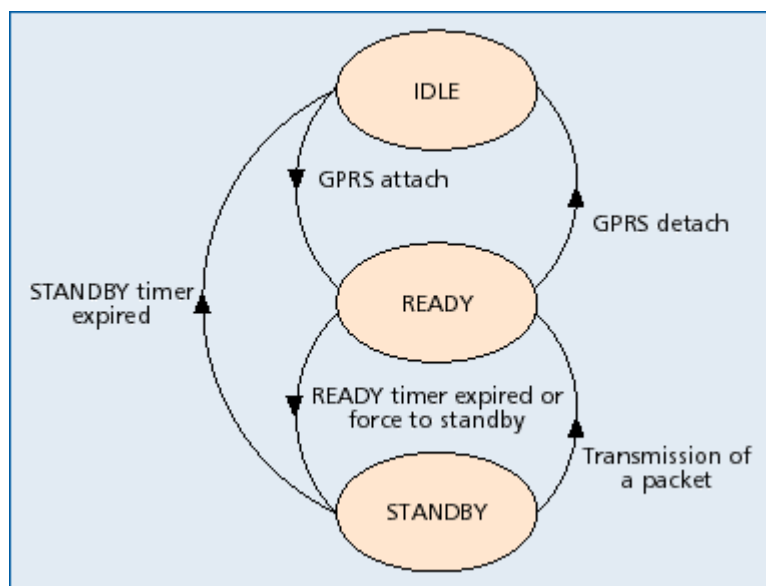

5. GPRS

IDLE . GPRS attach
 READY . GPRS detach
 IDLE
 STANDBY GRPS attach
 READY 가
 IDLE
 . READY SGSN
 . STANDBY , GSM
 LA(Location Area) RA(Routing Area) .⁸ RA

⁸ LA 가 RA

STANDBY RA (9) READY

RA SGSN "routing area update request"
 (6) RA ID(RAI: Routing Area Identity)
 SGSN BSS 가 CI(Cell Identifier) RAI 가

- Intra-SGSN RA (6): RA SGSN 가
 P-TMSI ("routing area update accept")
 가 GGSN HLR
- Inter-SGSN RA : RA , RA
 SGSN SGSN PDP SGSN
 SGSN GGSN 가
 HLR MSC/VLR SGSN

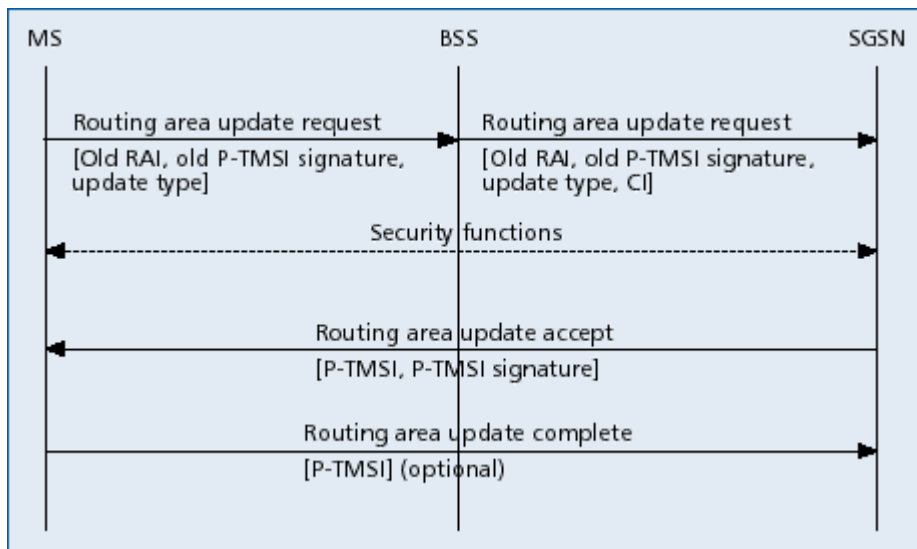

6. Intra-SGSN Routing Area

LA RA GPRS GSM

LA

SGSN "routing area update request"
 LA SGSN SGSN LA

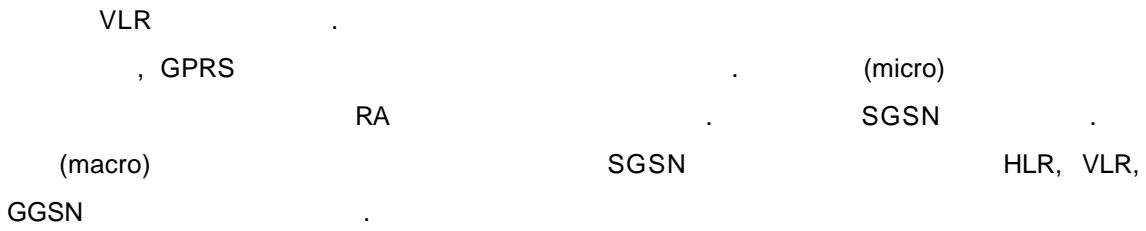

Air Interface – Physical Layer

Multiple Access and Radio Resource Management Principles

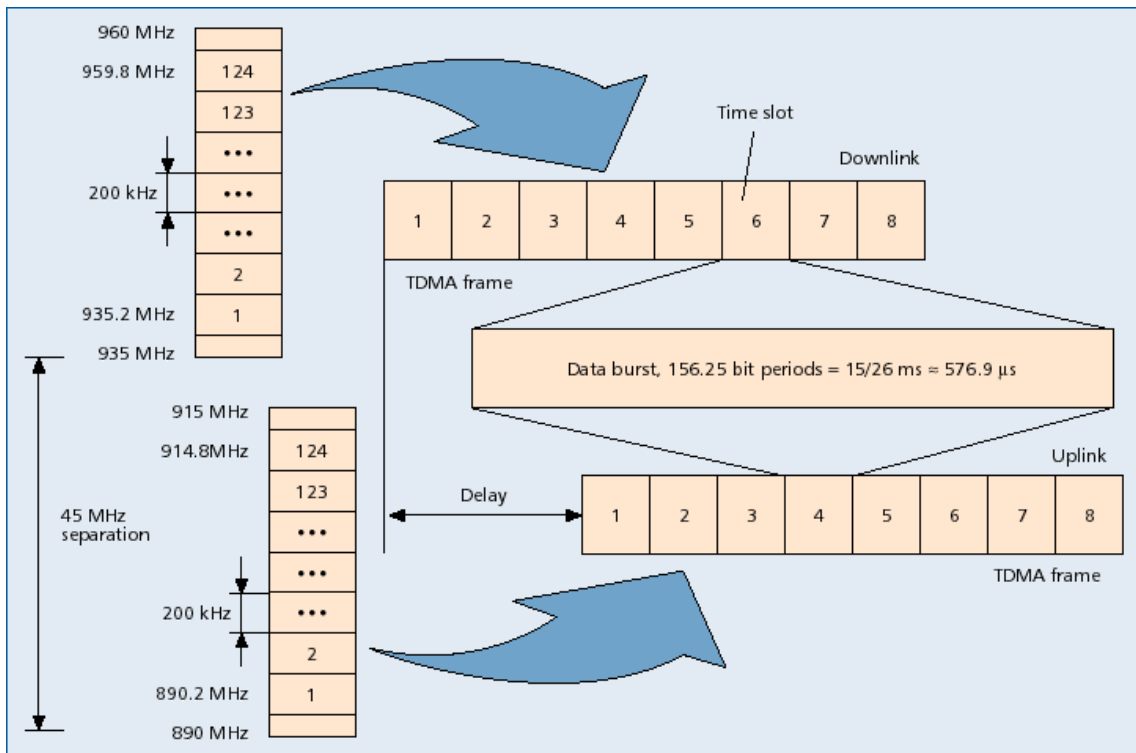

7. GSM (duplexing), TDMA

200KHz 8 (time slot) TDMA
. 8 TDMA . 15/26ms =

576.9us , TDMA 4.613ms . GSM

GPRS GSM 가 . GPRS TDMA

가 , GSM 1 8

GSM ()

, GPRS

GPRS GPRS

PDCH(Packet Data Channel) . PDCH 가

가 GPRS GPRS

[12]. PDCH

PDCH . GSM

가 PDCH GPRS

QoS 가 , PDCH

Logical Channels in GPRS

(synchronization),

3 GPRS [12].

GSM 가 , () .

PDTCH(Packet Data Traffic Channel) . PDTCH

PDTCH

PBCCH(Packet Broadcast Control Channel) BSS - -

. BSS GPRS

. GPRS

BCCH(Broadcast Control Channel)

Packet data traffic channel	PDTCH	Data traffic	MS ↔ BSS
Packet broadcast control channel	PBCCH	Broadcast control	MS ← BSS
Packet common control channel	PRACH PAGCH PPCH PNCH	Random access Access grant Paging Notification	MS → BSS MS ← BSS MS ← BSS MS ← BSS
Packet dedicated control channel	PACCH PTCCH	Associated control Timing advance control	MS ↔ BSS MS ↔ BSS

3. GPRS

PCCCH(Packet Common Control Channel)

- PRACH(Packet Random Access Channel) PDTCH
- PAGCH(Packet Access Grant Channel) PDTCH
- PPCH(Packet Paging Channel) BSS 가
- PNCH(Packet Notification Channel) PTM ()가
- PACCH(Packet Associated Control Channel) PDTCH ()
- PTCCH(Packet Timing Advance Control Channel)

PCCCH GSM CCCH
(Common Control Channel) PBCCH 가
BCCH(Broadcast Control Channel)
8 [12]. PRACH RACH
PAGCH AGCH
PDCH USF(Uplink

State Flag)

USF

9

[12].

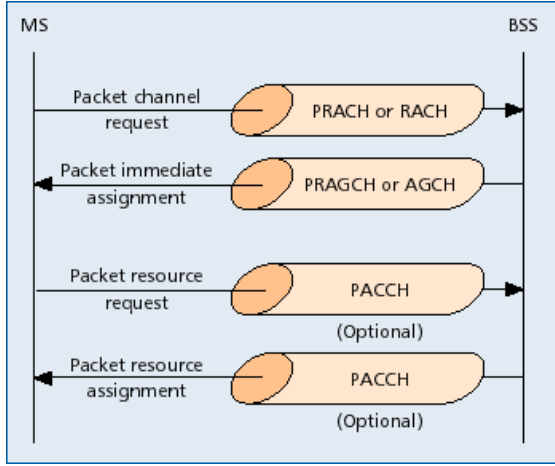

8.

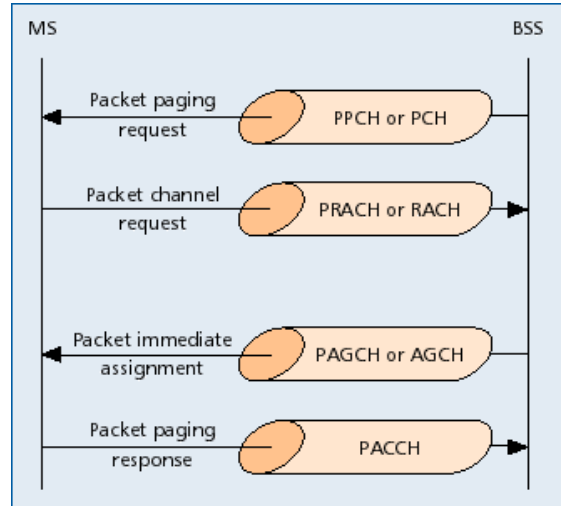

9.

Mapping of Packet Data Logical Channels onto Physical Channels

가 가 ;
 TDMA
 BTS TDMA
 . 52 TDMA
 PDCH 10 [13]. 4 TDMA
 (12 . B0 ~ B11) 2
 PTCCH , 2 (idle)

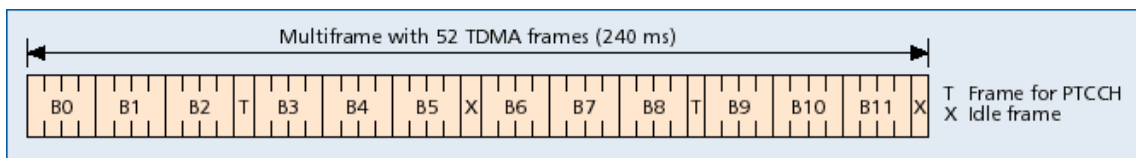

10. 52

B0 ~ B11

PBCCH

[13]

GPRS

52

, 51

PCCCH PBCCH

PDCH

Channel Coding⁹

. GPRS
 GSM (outer)
 (inner) (convolutional) (interleaving)
 4 [14]. 4

Coding scheme	Precod. USF	Infobits without USF	Parity bits BC	Tail bits	Output conv. encoder	Punct. bits	Code rate	Data rate kbits/s
CS-1	3	181	40	4	456	0	1/2	9.05
CS-2	6	268	16	4	588	132	~ 2/3	13.4
CS-3	6	312	16	4	676	220	~ 3/4	15.6
CS-4	12	428	16	-	456	-	1	21.4

4. GPRS

4 가 가
 , CS-1 GSM 9.05kbit/s
 가 ,
 21.4kbit/s . 8
 171.2kbit/s 가
 , 3
 가 CS-3 , 40kbit/s
 가 CS-1
 (codeword)
 , Viterbi
 [15].

Protocol Architecture

Transmission Plane

13 GPRS

9 가
 가

(flow control), (error detection), (error correction)

GPRS Backbone: SGSN – GGSN –

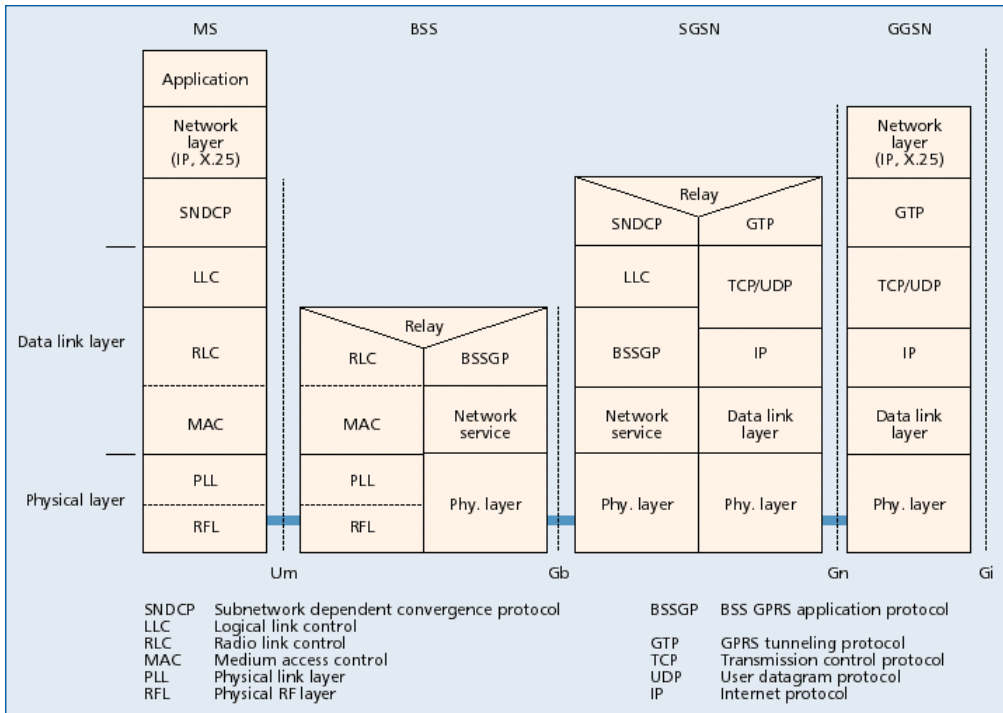
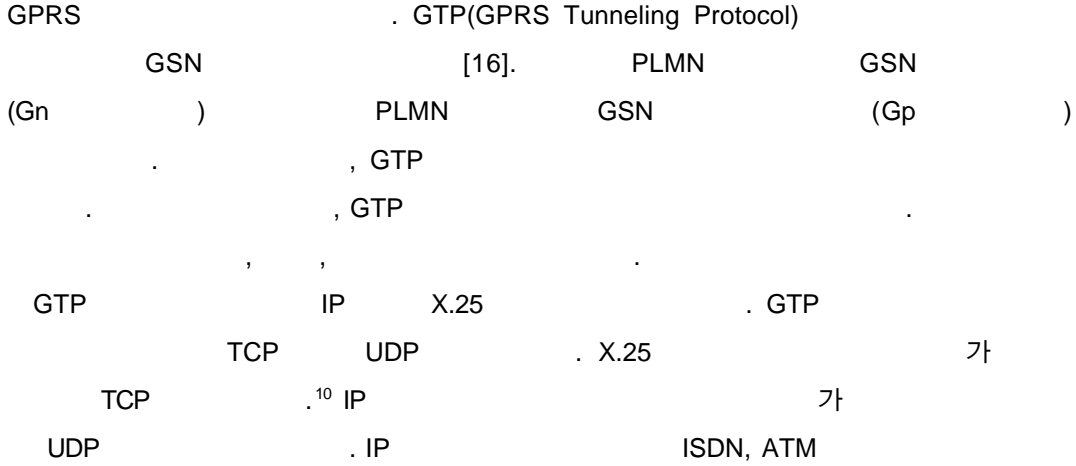

13. GPRS

, GPRS IP/X.25 over GTP over UDP/TCP

over IP 가 .

¹⁰ X.25 가 (virtual circuit switching)

가

SNDCP(Sub-network Dependent Convergence Protocol)¹¹ – SNDCP SGSN

[17].

- LLC 가
-

Air Interface – Um

: ; LLC (SGSN) RLC/MAC (2
 BSS)
 LLC SGSN [18].

HDLC

(ARQ: Automatic Repeat Request)

(acknowledged transmission)

(unacknowledged transmission)

GSM LAPDm [5].
 RLC/MAC 가 가 RLC(Radio Link Control)

BSS LLC
 RLC 가

. MAC(Medium Access Control)

QoS (scheduling) . GPRS MAC
 (contention resolution) slotted ALOHA [20]. RLC/MAC

: BSS 2
 ; PLL(Physical Link Layer) RFL(physical RF Layer)

PLL BSS

RFL PLL

¹¹ SGSN

SNDCP

BSS – SGSN – BSSGP(BSS GPRS Application Protocol) ¹² BSS SGSN

QoS
(Frame Relay)

Signaling Plane

[11]. GPRS attach/detach, PDP

SGSN GMM/SM(GPRS Mobility Management and Session Management) (14 .) GMM/SM GPRS attach/detach, PDP

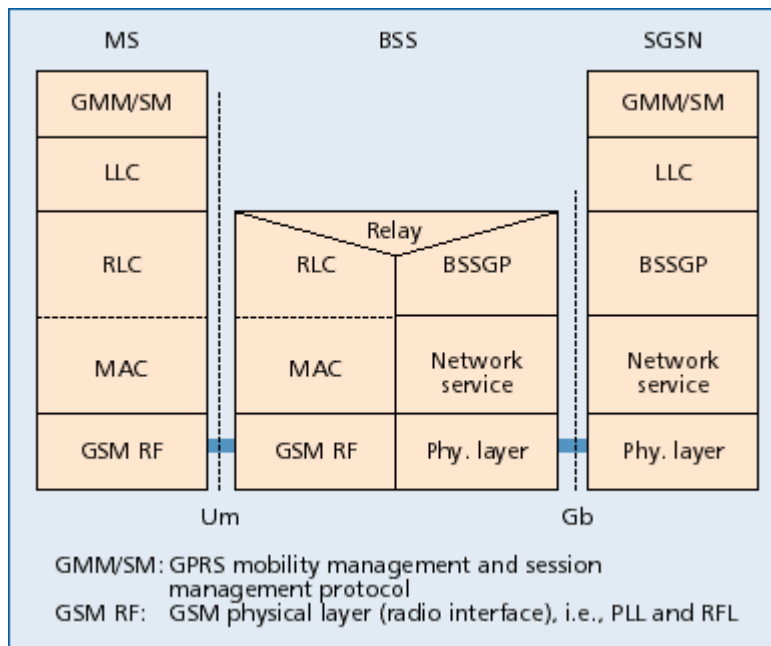

14. GPRS : MS – SGSN

SGSN HLR, VLR, EIR GSM (15, 16 .) GPRS . SGSN HLR SGSN EIR MAP(Mobile Application Part) . MAP SS7

¹² BSSGP 가

. SGSN BSS . QoS

MAP TCAP(Transaction Capabilities Application Part)
 SCCP(Signaling Connection Control Part) BSSAP+(Base Station System
 Application Part) GSM BSSAP BSSAP+ SGSN VLR (Gs
)
 GSM GPRS

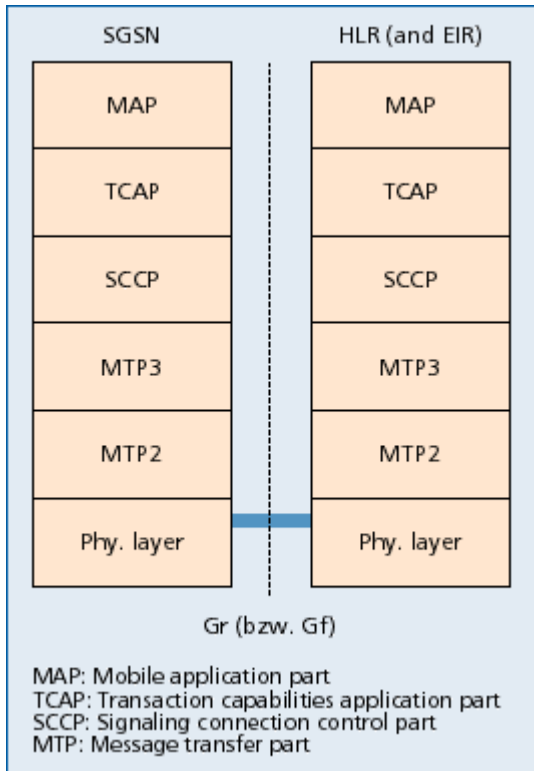

15. : SGSN – HLR & EIR

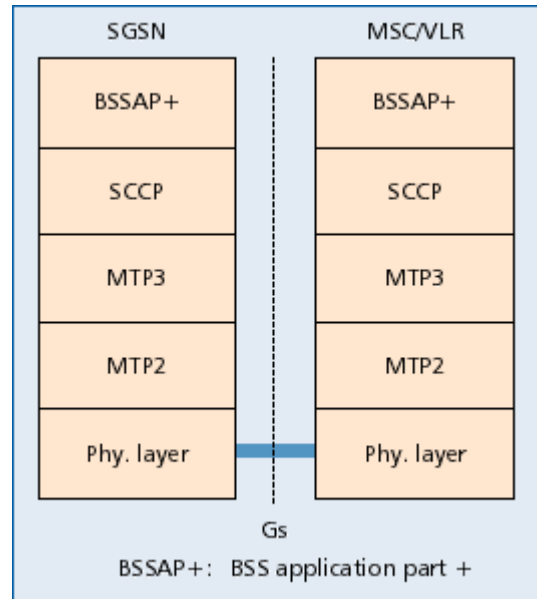

16. : SGSN – MSC/VLR

Inter-working with IP Networks

, GPRS IP
 . GPRS IPv4 IPv6 . 3 , Gi IP
 . IP , GPRS IP
 , GGSN IP . 17 GGSN
 가 [21].
 18 GPRS . IP
 GPRS IP . IP
 가 . IP
 IP . DHCP[22]

가 . GGSN PDP IP GSM
 . IP PLMN

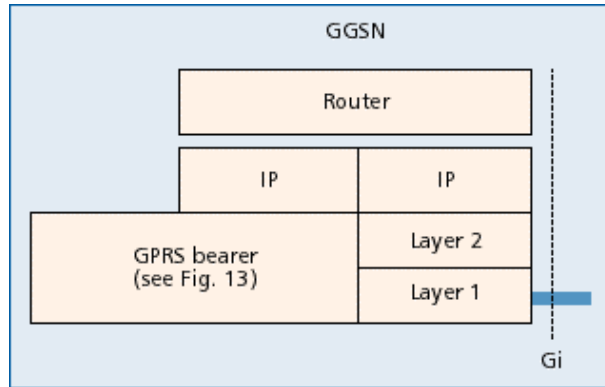

17. IP Gi

GPRS IP DNS[23] IP , GPRS
 가 . PLMN
 IP , GPRS

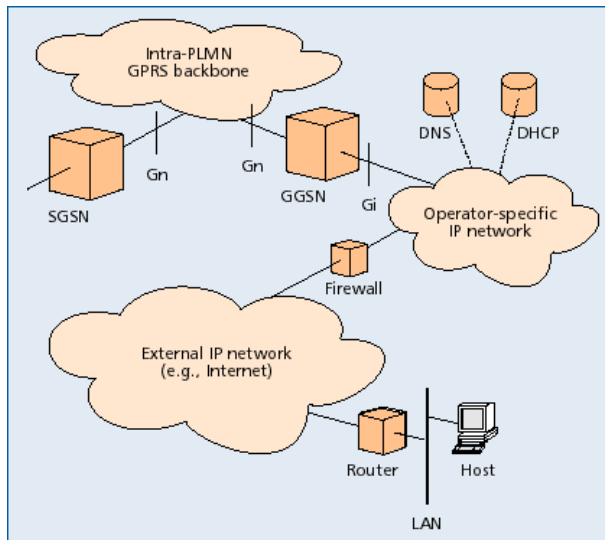

18. GPRS

Summary

GPRS 3 . GPRS 가

/

GPRS

가 SGSN GGSN GPRS , GPRS

가

GPRS - - SMS

- - . GPRS QoS

QoS , PDP

가 GSM GPRS

가

GPRS , PDP

(PDP , PDP , QoS, GGSN) . PDP 가 ,

GGSN . GGSN

SGSN . GPRS

RA . RA GSM LA

. GPRS 가

GSM GSM GPRS

. PDP

GPRS 가

GPRS . GPRS

1 8 TDMA

가 (GSM) (GPRS)

PDTCH . 1

(PBCCH) 4 (PRACH, PAGCH, PPCH, PNCH), 2

(PACCH, PTCCH) . GSM

GPRS

GPRS 4 가 ,
 가 . GPRS
 GPRS (GTP), GPRS
 (GMM/SM), BSS GPRS (BSSGP) GSM
 (MAP)
 GPRS IP

References

- [1] S. Faccin, Liangchi Hsu, R. Koodli, Khiem Le, and R. Purnadi, GPRS and IS-136 Integration for Flexible Network and Services Evolution, IEEE Personal Communications, vol. 6, no. 3, pp. 48-54, June 1999.
- [2] Press release, Neue Wege in der mobilen Datenkommunikation: T-Mobil fuhr General Packet Radio Service (GPRS) ein, Hannover/Bonn, Germany: T-Mobil (<http://www.t-mobil.de>), March 19, 1999.
- [3] Press release, Hochgeschwindigkeit fur das D2-Netz: Mit GPRS blitzschnell auf die Datenautobahn, Dusseldorf, Germany: Mannesmann Mobilfunk GmbH (<http://www.d2mannesmann.de>), August 9, 1999.
- [4] M. Rahnema, "Overview of the GSM System and Protocol Architecture," IEEE Communications, vol. 31, no. 4, pp. 92-100, April 1993.
- [5] J. Eberspacher and H.-J. Vogel, GSM: Switching, Services and Protocols, John Wiley & Sons, 1998.
- [6] G. Heine, GSM Networks: Protocols, Terminology, and Implementation, Artech House, 1999.
- [7] M. Mouly and M.-B. Pautet, The GSM System for Mobile Communications, Telecom Pub, 1992.
- [8] GSM 03.02, Network architecture.
- [9] GSM 02.60, GPRS, Service description, Stage 1.
- [10] G. Brasche and B. Walke, Concepts, Services, and Protocols of the New GSM Phase 2+ General Packet Radio Service, IEEE Communications, vol. 35, no. 8, pp. 94-104, August 1997.
- [11] GSM 03.60, GPRS, Service description, Stage 2.
- [12] GSM 03.64, GPRS, Overall description of the GPRS radio interface, Stage 2.
- [13] GSM 05.02, Multiplexing and multiple access on the radio path.
- [14] GSM 05.03, Channel coding.
- [15] R. Johannesson and K. Sh. Zigangirov, Fundamentals of Convolutional Codes, IEEE Press, 1999.

- [16] GSM 09.60, GPRS, GPRS Tunneling Protocol (GTP) across the Gn and Gp interface.
- [17] GSM 04.65, GPRS, MS-SGSN, Subnetwork Dependent Convergence Protocol (SNDCP).
- [18] GSM 04.64, GPRS, MS-SGSN, Logical Link Control (LLC) layer.
- [19] GSM 04.60, GPRS, MS-BSS interface, Radio Link Control / Medium Access Control (RLC/MAC) protocol.
- [20] D. Bertsekas and R. Gallager, Data Networks, Englewood Cliffs, Prentice Hall, 1987.
- [21] GSM 09.61, GPRS, Interworking between the PLMN supporting GPRS and Packet Data Networks (PDN).
- [22] R. Droms, Automated Configuration of TCP/IP with DHCP, IEEE Internet Computing, vol. 3, no. 4, pp. 45-53, July/August 1999.
- [23] P. V. Mockapetris, Domain Names: Concepts and Facilities, RFC 1034, 1987

Additional Reading

- [24] J. Cai and D. J. Goodman, General Packet Radio Service in GSM, IEEE Communications, vol. 35, no. 10, pp. 122-131, October 1997.
- [25] H. Granbohm and J. Wiklund, GPRS: General Packet Radio Service, Ericsson Review, vol. 76, no. 2, pp. 82-88, 1999.