

Case Study

VIAVI Data Center Case Study & Test Guide

Data centers have become the epicenters of the digital world, and thus continue to grow in speed, complexity, and importance. Whether an efficiently-run data center is a means to deliver a service, e.g. an Internet Content Provider (ICP), or if the data center is the primary business, e.g. a multi-tenant data center (MTDC) – testing is a critical element in meeting customer SLAs and/or internal performance objectives.

In a modern data center, there are thousands of links, cables, transponders, and connections, or put frankly – potential points of failure. With limited resources, where do you test? The following is a brief list of some key test use cases for data center operators.

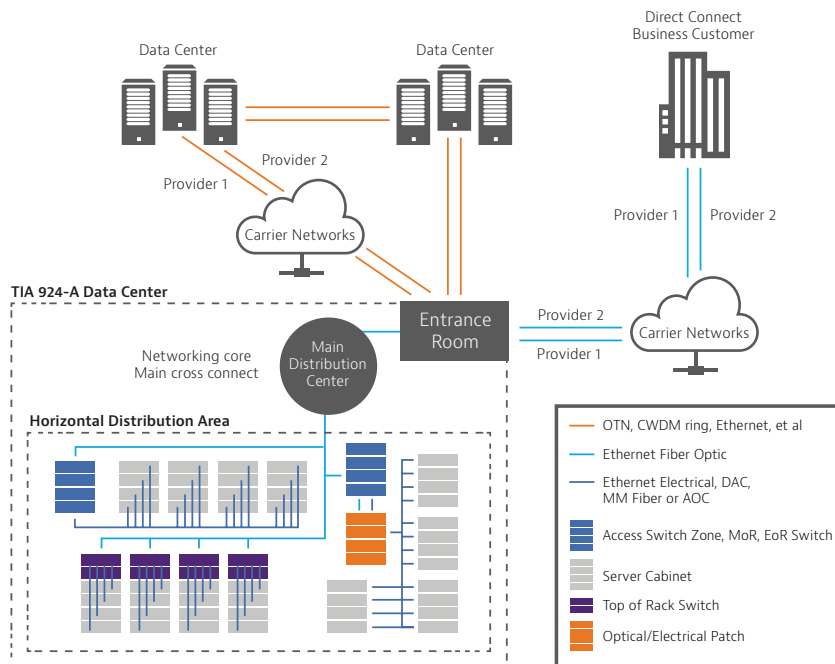

Use Case 1. Data Center to Data Center Interconnect (DCI) – Leased Connections

Problem:

Due to the importance of the data stored in data centers, most data center operators (DCOs) back up data to yet another data center to ensure quick disaster recovery (DR), and to safeguard their customers' business continuance (BC). Operators need that DC to DC transmission to happen as quickly as possible, so DCs are linked by very high-capacity connections in various protocols. To maintain the integrity of those connections, and to verify SLAs, a DCO tech needs to be to perform tests on Ethernet line rates up to 100G and beyond, as well as OTN, CWDM, or DWDM circuits.



Solution:

The VIAVI T-BERD/MTS 5800-100G is the most versatile test platform in the industry, able to perform tests on OTN, CWDM/DWDM, and Ethernet up to 100G with dual ports. Critical tests include industry-based

- RFC-2544
- Y.1564
- RFC-6349 TCP Throughput

In addition, with such big and critical circuits connecting data centers, testing the underlying fiber integrity on those circuits is also prudent. With the same hand-held tester, techs can also do fiber testing with a 4100 Series OTDR, making the T-BERD/MTS 5800-100G an essential tool for today's modern data center.

Use Case 2. Dark Fiber DCI

Problem:

Because of the criticality of DCI links, not to mention the expense, some DCOs are choosing to purchase or deploy their own dark fiber instead of leasing a managed service from a telco/MSO. Most likely dark fiber was originally deployed to carry 10G services and fiber certification/qualification tests (such as insertion loss, optic return loss, length, OTDR, dispersion (CD & PMD), attenuation profiles, etc.) were probably not performed because 10G services are less sensitive to those factors. Testing was not necessary as a result. The challenge is that DCOs aren't lighting dark fiber to put 10G on them, but 100G and more. If the dark fibers were not proofed for 100G, then service turn-up and performance could be problematic. Although 100G Coherent transponders use PMD compensation mechanisms, there are limits to what can be corrected/tolerated. Also, legacy fibers have more loss/attenuation variance from fiber to fiber, so a baseline is needed to ensure that the fiber and specific wavelengths can support the high speeds needed for DCI. Once in service, and specific to high speed ROADMs networks, Optical Signal to Noise Ratio (OSNR) needs to be validated as it directly correlates to the throughput performance (bit error rate) of a network link.



Solution:

The VIAVI T-BERD/MTS with Fiber Complete is a unique solution that enables bi-directional Insertion Loss (IL), Optical Return Loss (ORL) & OTDR testing from one optical port with a single press of a button. To complement Fiber Complete, the Optical Dispersion Modules (ODM) allow full fiber characterization of Chromatic Dispersion (CD), Polarization Mode Dispersion (PMD) and Attenuation Profile (AP) in under two minutes. Both applications use fully automated test scripts allowing for a full suite of fiber complete and fiber characterization tests. Optical Spectrum Analyzers (OSA) then allow for measurement of OSNR.

- Fiber Characterization for T-BERD/MTS-6000A & 8000
- ODM for T-BERD/MTS-6000A & 8000
- OSA-110x or OSA-500x modules for T-BERD/MTS-6000A or 8000

Use Case 3. 200G Data Center Interconnect (DCI)

Problem:

With ever-growing data loads, DCOs, and particularly ICPs, need to send more traffic between data centers. To address that trend, many DCOs are using DP-16QAM modulation to create 200G wavelengths over their DWDM systems, thereby doubling the capacity over the same fiber. While beneficial, the danger is not testing the system before adding live traffic to it. There may be limitations on a particular wavelength that prevent it from achieving a 200 Gbps transmission rate, limitations that cannot be known without stress testing the wavelength before putting it into service. Many DCOs don't test these new 200G links simply because they don't have the test capability.

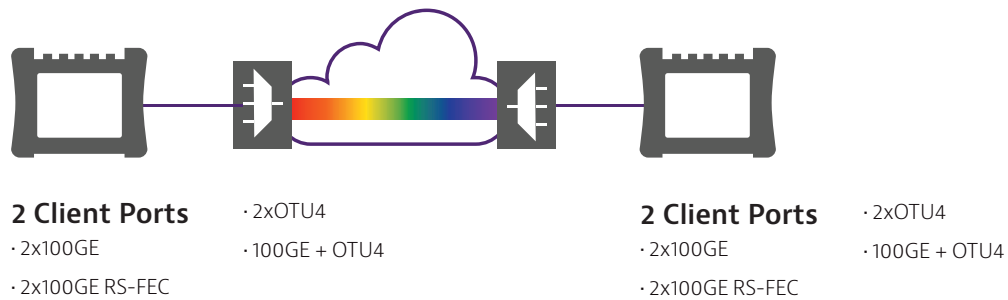

Solution:

With its two 100G ports, the VIAVI TBERD 5800-100G is one of the few field testers in the world that can stress test a data center's critical 200G WDM DCI link.

- QuickCheck
- RFC-2544
- Y.1564

Use Case 4. Customer-to-Data Center Connection

Problem:

A customer requires a private Ethernet circuit from their premises all the way to their rented rack or cage in the data center, or to a particular service provider in the DC. When customer application problems arise, the customer will call the DCO first, and the DCO must be able to test the transmission quality on the customer's circuit into the meet-me room as well as to the extended demarc as part of a standard SLA verification protocol.



Solution:

The VIAVI T-BERD/MTS 5800 hand-held network testers lets technicians quickly run several, standards-based tests on the circuit, regardless of the bandwidth, from a quick connectivity check to KPI verification - without being telecom experts. Tests include:

- RFC-2544
- Y.1564
- RFC-6349 TCP Throughput

DCOs can quickly determine if the customer circuit is the problem or not, and then take the appropriate next step.

Use Case 5. Ensuring Clean Fiber Connections

Problem:

A fiber cross-connect cable must be run from a service provider's POP inside the data center to the customer's extended demarc at their rack/cage, or between racks, which are patch panel to patch panel connections. These fiber connections have very strict loss budgets and are often the source of performance degradation. The addition of Multi-fiber Push On (MPO) connectors and ribbon fibers carrying 12 or 24 fibers in a single cable only complicates the situation.

Contaminated fiber connections are the #1 cause of troubleshooting and optical network downtime. Therefore, the most critical element to safeguarding quality fiber connections is ensuring a proper end-face condition. When working with fibers only a few microns wide, any contaminant can be catastrophic.

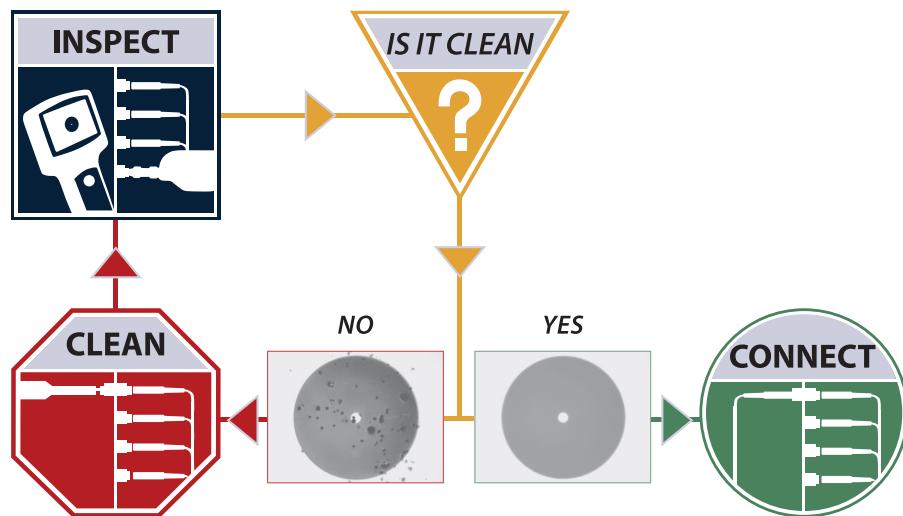

Solution:

At VIAVI, we recommend proactively inspecting all fiber connectors prior to ever connecting them. VIAVI fiber inspection solutions make it fast and easy to ensure that fiber inspection is maintained as a best practice whenever handling every fiber connector in the Data Center. Our award winning FiberChek probe microscope and FiberChek Sidewinder (optimized for MPO) provide fast, intuitive and automated fiber inspection capabilities in a single handheld device for both simplex and MPO fiber connections.

Use Case 6. Testing & Troubleshooting Physical Cabling Infrastructure

Problem:

While the physical cabling is initially installed and certified to industry standards during network construction, several factors can change after installation (usually during moves, adds, and changes [MACs]) that cause network problems and downtime. Some of these causes include electromagnetic interference (EMI) from copper cabling, reversed polarity in duplex & multi-fiber MPO connectors and excessive loss caused by contaminated fiber end-faces, physical stress (micro- or macro-bends) not transmitting light properly. These issues must be identified and eliminated as a problem's root-cause.

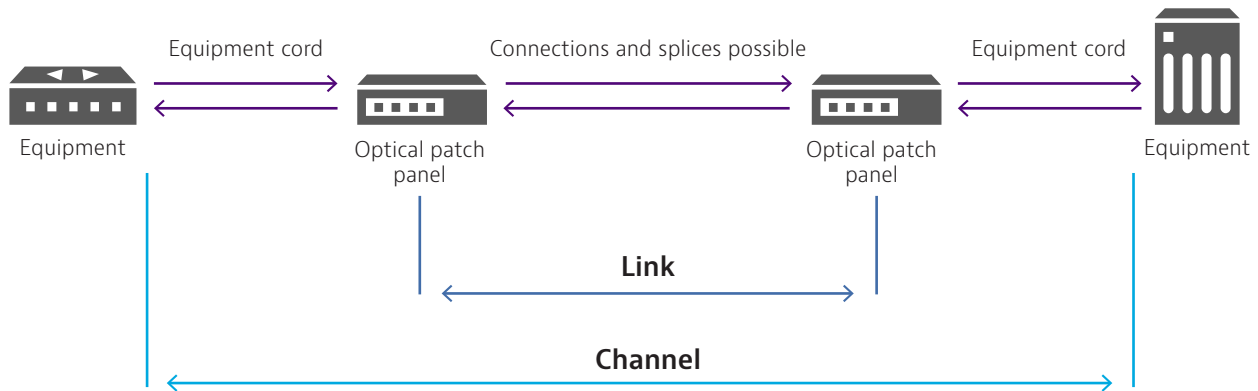

Solution:

Those cross-connect cables should be certified against industry standards. The VIAVI OLTS and MPOLx optic loss test sets provide the necessary tests for basic tier 1 fiber certification of length, optic loss and correct polarity (especially important with MPO) enabling fast and accurate testing for single and multi-mode fibers with generation of certification reports. Similarly, the VIAVI TBERD2000 provides an all-in-one solution to troubleshoot network issues by pinpointing the exact location of any event causing excessive loss. For copper testing, the Certifier10G gives technicians the ability to test for length, loss, and polarity, while the Certifier40G can test BOTH copper or fiber optic cables quickly and accurately. This insures that cables were terminated and installed properly and are capable of supporting the stringent demands of today's datacenters.

- Certifier40G
- MPOLx MPO Optic Loss Test Set
- OLTS-85 Optic Loss Test Set
- Smart Pocket OLS-34, 35, 38 Light Source
- PowerChek OP-1 Optical Power meter
- vTB/MTS-2000 OTDR or SmartOTDR
- FFL-050/-100 Visual Fault Locator
- FI-60 Live Fiber Identifier

Use Case 7. Active Optical Cable/Direct Attach Copper Test

Problem:

An active optical cable (AOC), which is a fiberized cable based on multimode fibers terminated by pluggable optic cages such as QSFP or SFP, needs to be run within a rack, a row, or between adjacent rows inside the data center. Direct Attach Copper (DAC) is similar but it's with copper cables. The AOC can, for instance, be used to connect a TOR (Top of Rack) switch to a Leaf/Spine. Such cables are typically used for short reach high-speed connections at 40GE or 100GE or 25GE. These AOC/DAC cables may be the cause of errors due to defects such as wrong polarities (crossover Type-B versus straight Type-A or manufacturing defect), excessive bends, or potentially crushed or squeezed optical fibers, or EMI issues with DACs. Errors can be identified BEFORE cables are laid avoiding extra effort to replace the cable. Alternatively, it is possible to troubleshoot a cable which has already been laid when a link will not come up. At a cost of US\$1,000 apiece and more, a DCO wants to avoid mistakenly throwing away good AOC cables.

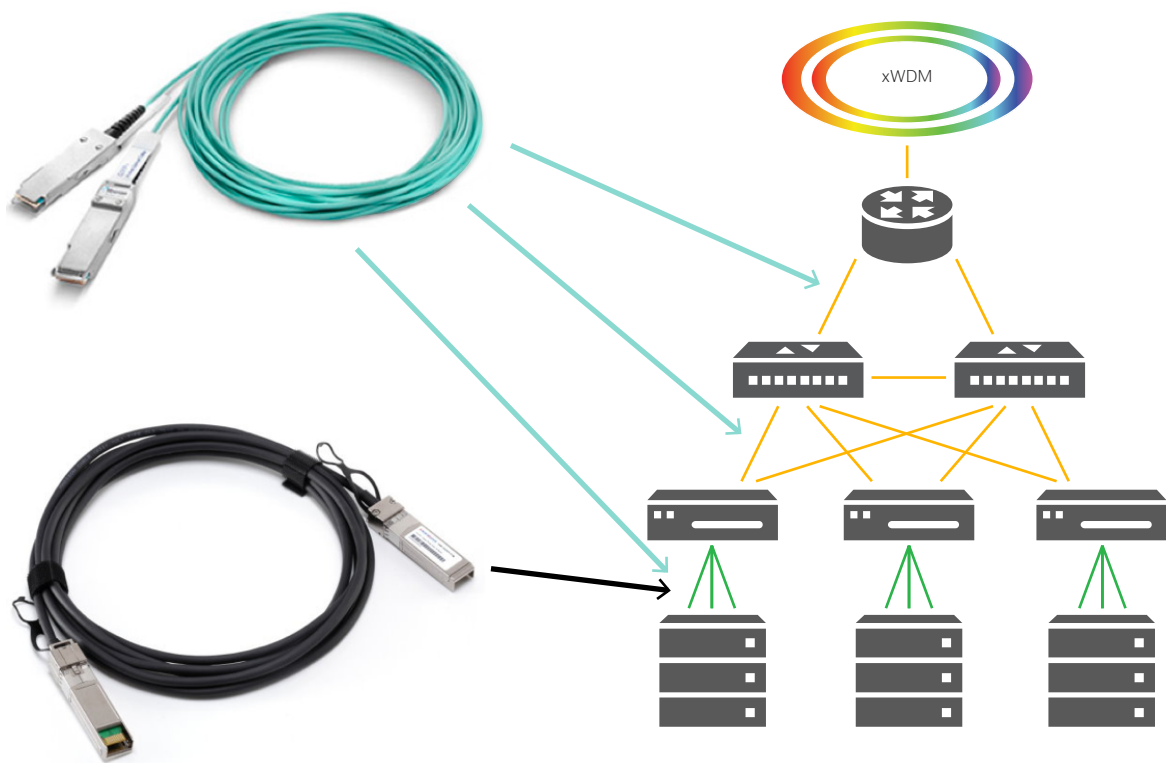

Solution:

Such AOC/DAC cables should be tested against transmission defects with a Bit Error Rate test. The VIAVI T-BERD 5800-100G with the cable test script and report capabilities provides dual SFP28/QSFP+/QSFP28 ports for quick and efficient testing of AOC/DAC cables.

Use Case 8. Optics Self-Test

Problem:

The pluggable, optical transceiver modules (QSFP, CFPx and SFPx) on the ends of those cross-connect cables must also be checked to ensure they are working optimally.

Solution:

The T-BERD/MTS 5800-100G Optics Self-Test is a workflow tool to verify and troubleshoot performance issues related to high-speed optics. It is especially well suited to data center environments and helps isolate pluggable optics issues. This easy-to-use test integrates items such as a bit error theory algorithm, clock offset verification, and per-lambda power monitoring. Coupled with RS-FEC (25GE & 100GE), it offers pre-FEC and post-FEC testing.

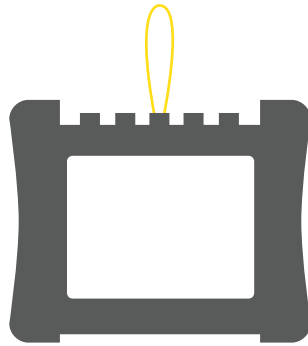

Use Case 9. Intra Data Center Bit Error Rate Testing

Problem:

A DC tenant wants to know about the transmission performance within the data center, from POP to the rack, or from the rack to another service provider on another floor, etc. The transmission quality is likely very high, however the DCO has no way to provide the customer with a measurement and a report to verify the SLA.

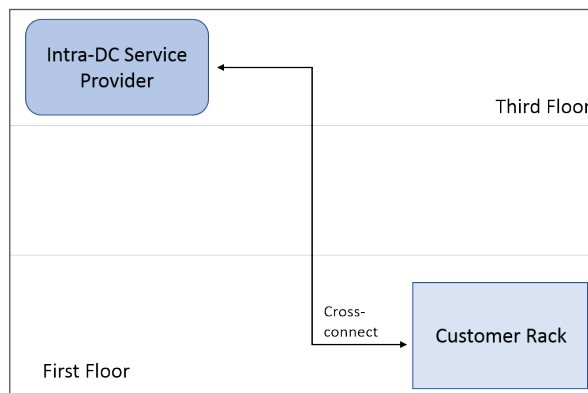

Solution:

The VIAVI T-BERD/MTS 5800 provides precise measurements of network KPIs (latency/packet delay, frame loss, jitter/inter-packet delay variation, and burstability) down to the nano second, which are required for such short network links. In addition, for every test conducted the 5800 generates an easy to read report that can be printed out, e-mailed to the customer, or stored in the cloud via StrataSync.

Use Case 10. Fiber Monitoring

Problem:

The optical connections between data centers are mission-critical, so DCOs want to constantly monitor those fiber links and be quickly alerted to any fiber degradation, intrusion, especially a cut. Without the proper technology and alarm system, it can take days to identify and pinpoint the location of the cut, negatively impacting customer SLAs.



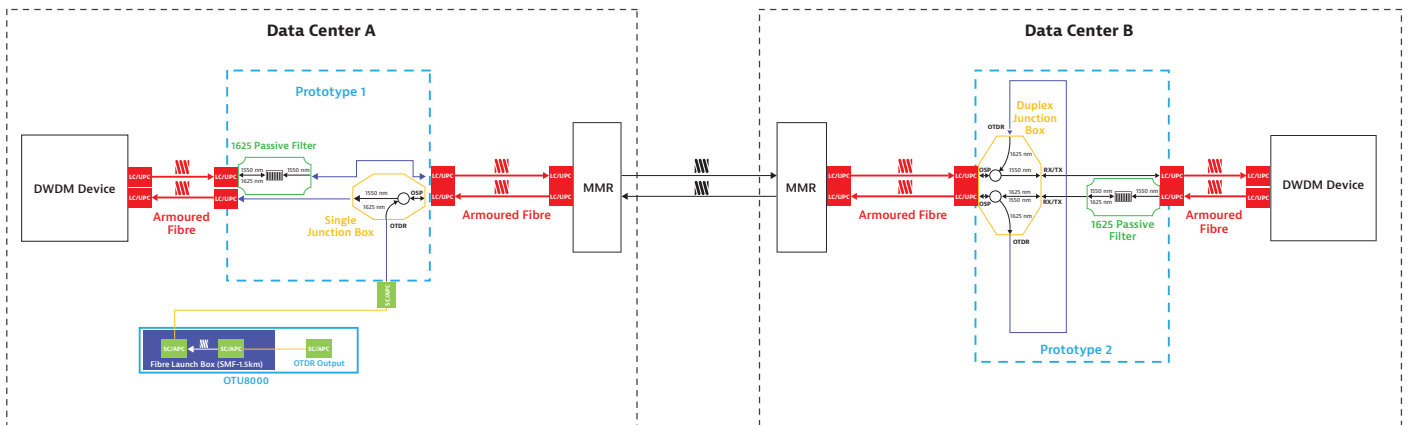

A second consideration, and potentially more important, is data security and being able to quickly detect network intrusions. Tapping into a fiber network can't be seen by monitoring the data layer and these non-intrusive taps give access to 100% of data traversing a fiber link. The good news is that tapping a location can be detected by fiber monitoring.

Solution:





The VIAVI SmartOTU is a rack-mounted OTDR that continuously monitors critical fibers in small optical networks. It can be run right out of the box with no training or IT configuration. When a fiber event occurs, it alerts users within minutes (email, SMS or SNMP) to help lower MTTR, improve network security, and boost SLA performance



Use Case 1. Data Center to Data Center Interconnection – Leased Connections





VIAVI Package	Products in package	Product Link	Photo
TB5800-GE-100GE	TBERD/MTS 5800-100G	www.viavisolutions.com/en-us/products/t-berd-5800-100g	
MTS5800-GE-100GE	P5000i	www.viavisolutions.com/en-us/products/p5000i-fiber-microscope	
TB5800-100GE or TB5800-100GE-SR4	TBERD 5800-100G	www.viavisolutions.com/en-us/products/t-berd-5800-100g	
MTS5800-100GE or MTS5800-100GE-SR4	P5000i	www.viavisolutions.com/en-us/products/p5000i-fiber-microscope	
TB5800-1G-10GE	TBERD/MTS 5800v2	www.viavisolutions.com/en-us/products/t-berd-5800-handheld-network-tester	
MTS5822P-1G-10GE-DP	P5000i	www.viavisolutions.com/en-us/products/p5000i-fiber-microscope	

Use Case 2. Data Center to Data Center Interconnection – Dark Fiber



VIAVI Package	Products in package	Product Link	Photo
TB5800-1G-10GE-C5LSLAYER4-C510GLAYER4	T-BERD/MTS-5800v2	www.viavisolutions.com/en-us/products/t-berd-5800-handheld-network-tester	
	TrueSpeed VNF	www.viavisolutions.com/en-us/products/truespeed-vnf	
TB5800-1G-10GE-C5LSLAYER4-C510GLAYER4	T-BERD/MTS-5800v2	www.viavisolutions.com/en-us/products/t-berd-5800-handheld-network-tester	
	TrueSpeed VNF	www.viavisolutions.com/en-us/products/truespeed-vnf	
Existing T-BERD/MTS-5800 owners can add the L4 option	TrueSpeed VNF	www.viavisolutions.com/en-us/products/truespeed-vnf	

Note: Fiber Complete will soon be available on TB/MTS-5800 so it can be coupled with a 2000 or another 5800

Use Case 3. 200G Data Center Interconnect (DCI)

VIAVI Package	Products in package	Product Link	Photo
TB5800-GE-100GE & C5DUAL100G	TBERD/MTS 5800-100G	www.viavisolutions.com/en-us/products/t-berd-5800-100g	
MTS5800-GE-100GE & C5DUAL100G	P5000i	www.viavisolutions.com/en-us/products/p5000i-fiber-microscope	
TB5800-100GE or TB5800-100GE-SR4 & C5DUAL100G	TBERD 5800-100G	www.viavisolutions.com/en-us/products/t-berd-5800-100g	
MTS5800-100GE or MTS5800-100GE-SR4 & C5DUAL100G	P5000i	www.viavisolutions.com/en-us/products/p5000i-fiber-microscope	

Use Case 4. Customer to Data Center Connection

VIAVI Package	Products in package	Product Link	Photo
TB5800-1G-10GE- C5LSLAYER4-C510GLAYER4	TBERD 5800v2	www.viavisolutions.com/en-us/products/t-berd-5800-handheld-network-tester	
TB5800-1G-10GE- C5LSLAYER4-C510GLAYER4	TBERD 5800v2	www.viavisolutions.com/en-us/products/t-berd-5800-handheld-network-tester	
Existing TBERD 5800 owners can add the L4 option	TrueSpeed VNF	https://www.viavisolutions.com/en-us/literature/truespeed-vnf-product-and-solution-briefs.pdf	









Use Case 5. Ensuring Clean Fiber Connections

VIAVI Package	Products in package	Product Link	Photo
FIT-FC-KIT3	FiberChek Probe w/ LC & SC Tips	http://www.viavisolutions.com/en-us/products/fiberchek-probe-microscope	
FIT-SP-2	PowerChek OPM w/ LC & SC Adapters	http://www.viavisolutions.com/en-us/products/powerchek-op-1-optical-power-meter	
NGC-500-6A	Certifier10G	http://www.viavisolutions.com/en-us/products/certifier40g	
NGC-4500-CuQEF-NA	Certifier40G Copper & Fiber (MM EF, SM)	http://www.viavisolutions.com/en-us/products/certifier40g	
TB2-DIS-QUAD-SLM	TBERD 2000 Quad w/ SLM & PMVFL	http://www.viavisolutions.com/en-us/products/tberd-2000-handheld-modular-test-set	

Use Case 6. Testing & Troubleshooting Physical Cabling Infrastructure

VIAVI Package	Products in package	Product Link	Photo
FIT-FC-KIT3	FiberChek Probe w/ LC & SC Tips	http://www.viavisolutions.com/en-us/products/fiberchek-probe-microscope	
FIT-SP-2	PowerChek OPM w/ LC & SC Adapters	http://www.viavisolutions.com/en-us/products/powerchek-op-1-optical-power-meter	
NGC-500-6A	Certifier10G	http://www.viavisolutions.com/en-us/products/certifier40g	
NGC-4500-CuQEF-NA	"Certifier40G Copper & Fiber (MM EF, SM)	http://www.viavisolutions.com/en-us/products/certifier40g	
TB2-DIS-QUAD-SLM	TBERD 2000 Quad w/ SLM & PMVFL	http://www.viavisolutions.com/en-us/products/tberd-2000-handheld-modular-test-set	





Use Case 7. AOC/DAC stand-alone cable testing

VIAVI Package	Products in package	Product Link	Photo
TBDC-100GE-AOCDAC	T-BERD/MTS 100GE Data Center Optical or Copper Cable Testing	www.viavisolutions.com/en-us/products/t-berd-5800-100g	
MTSDC-100GE-AOCDAC		www.viavisolutions.com/en-us/products/t-berd-5800-handheld-network-tester	
TBDC-40GE-AOCDAC	T-BERD/MTS 40GE Data Center Optical or Copper Cable Testing	www.viavisolutions.com/en-us/products/mts-5800-100g	
MTSDC-40GE-AOCDAC		www.viavisolutions.com/en-us/products/mts-5800-handheld-network-tester	
TBDC-25GE-AOCDAC	T-BERD/MTS 25GE Data Center Optical or Copper Cable Testing	www.viavisolutions.com/en-us/products/t-berd-5800-100g	
MTSDC-25GE-AOCDAC		www.viavisolutions.com/en-us/products/t-berd-5800-100g	
TBDC-10GE-AOCDAC	T-BERD/MTS 5822P Data Center Optical or Copper Cable Testing	www.viavisolutions.com/en-us/products/t-berd-5800-handheld-network-tester	
MTSDC-10GE-AOCDAC		www.viavisolutions.com/en-us/products/t-berd-5800-handheld-network-tester	

Use Case 8. Optics Self Test

VIAVI Package	Products in package	Product Link	Photo
TB5800-100GE	TBERD/MTS 5800-100G	www.viavisolutions.com/en-us/products/t-berd-5800-100g	
MTS5800-100GE		www.viavisolutions.com/en-us/products/t-berd-5800-100g	
TB5800-GE-100GE	TBERD/MTS 5800-100G	www.viavisolutions.com/en-us/products/t-berd-5800-100g	
MTS5800-GE-100GE		www.viavisolutions.com/en-us/products/t-berd-5800-100g	

Use Case 9. Intra data center BER test

VIAVI Package	Products in package	Product Link	Photo
TB5800-GE-100GE	TBERD/MTS 5800-100G	www.viavisolutions.com/en-us/products/t-berd-5800-100g	
MTS5800-GE-100GE	P5000i	www.viavisolutions.com/en-us/products/p5000i-fiber-microscope	
TB5800-100GE	TBERD/MTS 5800-100G	www.viavisolutions.com/en-us/products/t-berd-5800-100g	
MTS5800-100GE	P5000i	www.viavisolutions.com/en-us/products/p5000i-fiber-microscope	

Use Case 10. Fiber Monitoring

VIAVI Package	Products in package	Product Link	Photo
OTU8000	Smart OTU equipped with OTDR @ 1625 nm 45 dB	https://www.viavisolutions.com/en-us/literature/otu-8000-optical-test-unit-data-sheets-en.pdf	