

# T-BERD®/MTS-5800-100G

## All-in-one handheld network and fiber testing

The T-BERD/MTS-5800-100G handheld network tester is the one tool that network technicians and engineers need to install and maintain their networks. It supports both legacy and emerging technologies to address network applications including metro/core, data center interconnect, and business services test applications.

The industry's smallest handheld, dual-port 100G test instrument can test throughout the life cycle of a network service, including fiber testing, service activation, troubleshooting, and maintenance. Equipped with latest technology interfaces including SFP/SFP+/SFP28 and QSFP+/QSFP28/CFP4, the 5800-100G provides the investment protection needed to manage network growth while keeping customer satisfaction high. With advanced test features such as Optics Self-Test, high-Speed cable testing for data centers, Ethernet line rate capture/decode, and OTN Check, technicians can now test their networks faster and more accurately than ever before.

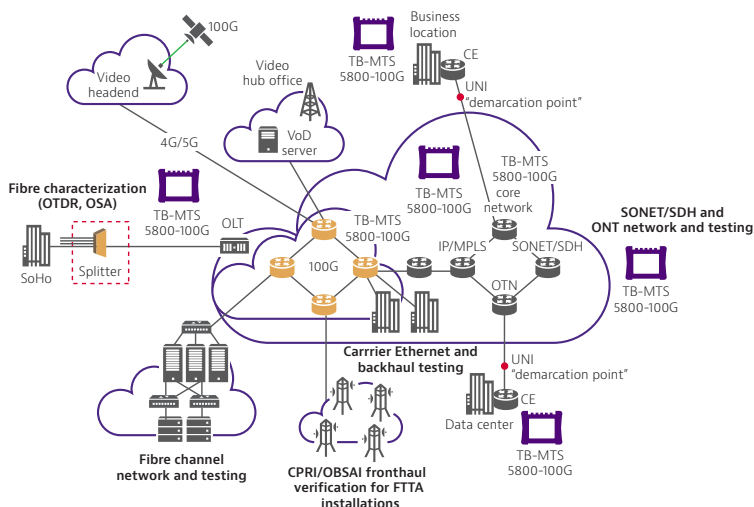

### Key Benefits

- Simplifies multi-technology testing with an all-in one dual 100 G handheld unit
- Optimized for field use with a multitouch screen, scripted workflows, and clear pass/fail results
- Complete support of protocols including Ethernet, OTN, SONET/SDH, PDH, Fibre Channel up to 32G, CPRI
- Speeds up fiber optics testing, Ethernet service activation, and troubleshooting tests

### Key Functions

- Supports comprehensive rate testing ranging from DSx PDH (1.5M/2M) through to 112G OTU4
- Saves time with the industry's fastest RFC 2544 and Y1564 SAMComplete™ Ethernet service activation test including nanosecond accurate latency measurements. Also supports RFC 6349 TrueSpeed
- Ensures QSFP+/QSFP28 and CFP4 modules run error-free with the field optimized Optics Self Test
- Provides speed and efficiency in testing OTN service activation with the OTN Check workflow automated script
- Supports VIAVI's 4100-Series OTDR and COSA modules with Smart Link
- Tests synchronization and timing using the TEM (Timing Expansion Module)

### Applications

- Converged Ethernet/IP network testing and troubleshooting at 10 Mbps to 100 G interfaces for data centers and core/metro networks
- Fiber link characterization and troubleshooting
- Installation and maintenance of OTN and legacy SONET/SDH and DSx/PDH networks
- Mobile and backhaul characterization, validation, and troubleshooting including synchronization. 5G-ready.

## All-in-One Handheld Tool

The configurable T-BERD/MTS-5800-100G is the industry's smallest dual-port 100G handheld test instrument. It can test a wide range of interfaces such as Ethernet, SONET/SDH, OTN, PDH, Fibre Channel, and CPRI.

- Compact form factor for easy portability: 7 x 9.5 x 3.2 in (17.8 x 24.1 x 8 cm)
- Large 7 in multi-touch display
- Tablet-like interface for easy navigation through test information and advanced workflows
- Integrated WiFi and Bluetooth lets you easily connect test sets and offload results
- Support of SmartAccess Anywhere providing an easy interface from an Android device or PC
- Support of cloud based StrataSync™ for asset management and result-data management

## Compatible with VIAVI Solutions Fiber Test Tools

Metro/longhaul, business services, and data center technicians can test virtually any interface in a network as well as qualifying fiber plants with one handheld instrument. The T-BERD/MTS-5800-100G is compatible with:

- The P5000i fiber microscope for connector end-face inspection and analysis
- MP-Series optical power meters for optical power and loss measurements
- OTDR modules for fiber link characterization and fault finding Smart Link Mapper optical analysis software that displays OTDR results in a simple, icon-based map view for clear diagnostics of detected issues
- COSA, a CWDM Optical Spectrum Analyzer

## Optimized for Easy Field Use

- Fixed test interfaces eliminate loose pluggable modules
- LEDs indicate plug-ins for tests
- A streamlined user interface provides simple pass/fail, green/red results
- Extended battery life enables longer test times and offload results
- Boots up rapidly from power-on to test start
- Dual-port operation runs two tests simultaneously, including two 100 G/high-speed tests
- Expandable with support for additional modules such as the TEM (Timing Expansion Module) for network synchronization and timing

## 5800-100G HWSupports multiple independent concurrent applications

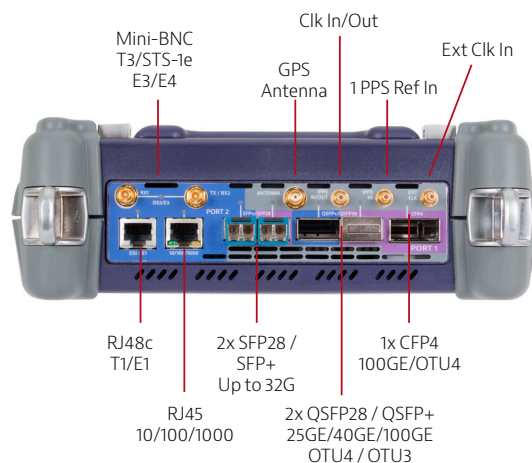

2x SFP+/SFP28  
1-10G Ethernet LAN/WAN  
OTN 1-1e/2/2e  
STM-1-64 & OC3-192  
Fibre Channel: 1,2,4,8,10,16G, 32G FC  
CPRI 614M – 10.1G

## Troubleshooting with Optics Self-Test/Cable Test

Optics Self-Test is a workflow tool to verify and troubleshoot performance issues related to high-speed optics. It is especially well suited to field environments and helps isolate pluggable optics issues. This easy-to-use test integrates items such as a bit error theory algorithm, clock offset verification, and per-lambda power monitoring. Coupled with RS-FEC, it offers pre-FEC and post-FEC testing.

## AOC/DAC Cable Test

Cable Test is tailor-made to test high-speed Active Optical Cables (AOC) and Direct Attach Copper (DAC) cables inside the data center. Such cables may be the cause of errors due to defects such as reversed polarities or squeezed fibers. Errors can be identified before cables are laid avoiding extra effort to replace the cable. The 5800-100G provides a slick built-in script with test report which captures the cable serial number.



## Time-Saving Ethernet Service Activation

Test more quickly and efficiently using automated tests combined into one integrated module covering electrical, Gigabit optical, 10 Gbps, 40 Gbps, and 100 Gbps Ethernet:

- QuickCheck — a fast, automated test that validates end-to-end configurations; runs as a pre-check test before RFC 2544 or Y.1564 or as a stand-alone test
- Enhanced RFC 2544 — an automated turn-up test with built-in time efficiency for validating key performance indicators (KPIs), concurrently measuring throughput, frame delay, and frame delay variation in addition to frame loss and committed burst size (CBS)
- Y.1564 SAMComplete™ — An automated service verification test that speeds the verification of multiple classes of service (COS) or connections based on SLAs
- High-accuracy latency — integrated into RFC 2544 and Y.1564 SAMComplete; CSAM provides 10 ns resolution and an accuracy of  $\pm 65$  ns or better at 100 GE and offload results
- TrueSpeed™ — an automated, RFC 6349-based TCP test that can save up to 25% on OpEx and reveals the causes of service degradation such as slow file downloads; this test suite especially helps eliminate finger pointing

Virtual Lane ID	Skew (Bts)	Skew (ns)	Sync Acquired	Marker Lock	Code Violations	Invalid Algn. Mirrs.
0	47	9.12	✓ ON	✓ ON	0	0
1	48	9.31	✓ ON	✓ ON	0	0
2	1,033	200.34	✓ ON	✓ ON	129	0
3	33	6.40	✓ ON	✓ ON	0	0
4	38	7.37	✓ ON	✓ ON	0	0
5	1	0.19	✓ ON	✓ ON	0	0
6	0	0.00	✓ ON	✓ ON	0	0
7	0	0.00	✓ ON	✓ ON	0	0
8	10	1.94	✓ ON	✓ ON	0	0
9	6	1.16	✓ ON	✓ ON	0	0

Per-lane Results

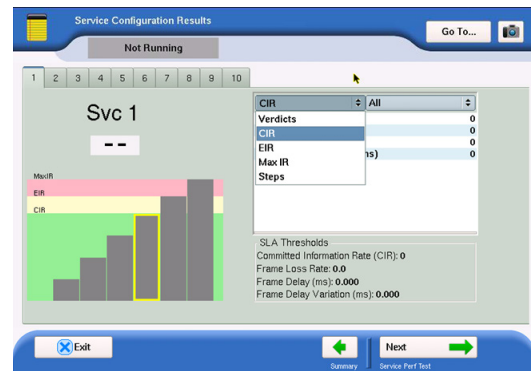

Y1564 SAMComplete

## More Ethernet Testing

5800-100G provides further depth to test Ethernet with additional functionality:

- RS-FEC testing for interfaces such as IEEE 802.3 SR4. Required for data center and short reach testing
- Capture and decode — available at all Ethernet rates; includes decodes with integrated Wireshark and the VIAVI built-in J-Mentor troubleshooting tool providing post-analysis problem identification
- IPv4 and IPv6 support including RFC 2544 and Y.1564 SAMComplete
- Layer 2 transparency testing with J-Proof — confirms end-to-end transparency between two endpoints anywhere in a network using control plane protocol data unit (PDU) information; examples include messages such as STP, GARP, and Cisco® CDP
- Operator lab evaluation tools — includes functionality such as skew injection, and per-lane alarms/errors injection, and reporting
- Ethernet Service Disruption with multi-tier triggers

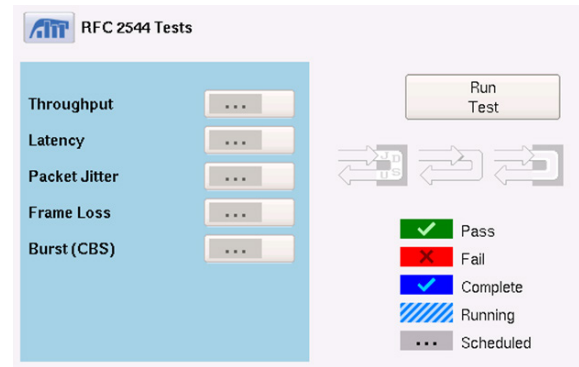

Enhanced RFC 2544

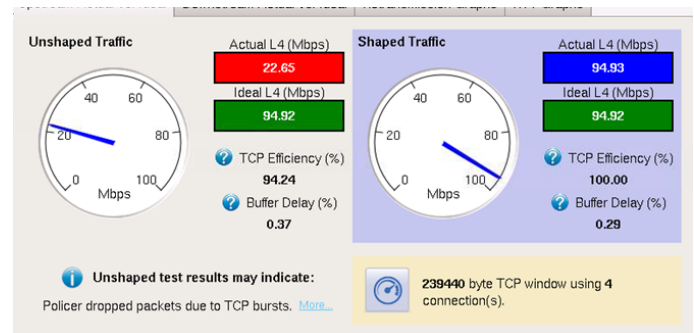
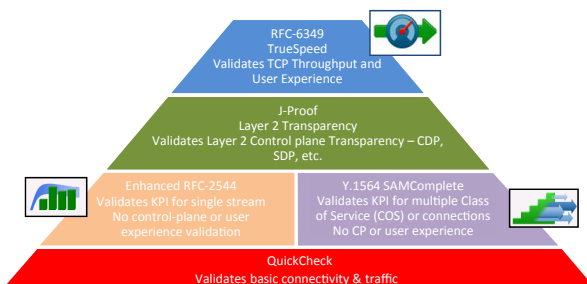

RFC 6349-based TrueSpeed™

## OTN Service Activation with OTN Check

The unique VIAVI OTN Check tool provides great efficiencies in testing OTN services. This workflow tool automates the process of turning up a new OTN service by integrating key tests that include OTN payload verification, round-trip delay, and network management transparency. It is offered at all OTN line rates. OTN Check greatly simplifies the process for users and generates a report with pass/fail results.

Functionality includes the following:

- RFC 2544 for Ethernet clients in OTN
- Complete ODU multiplexing mappings with nested ODU functionality including ODU0, ODU1, ODU2/2e, ODU3, and ODUFLEX.
- FEC testing for correctable and uncorrectable errors
- All 6 TCMs concurrently

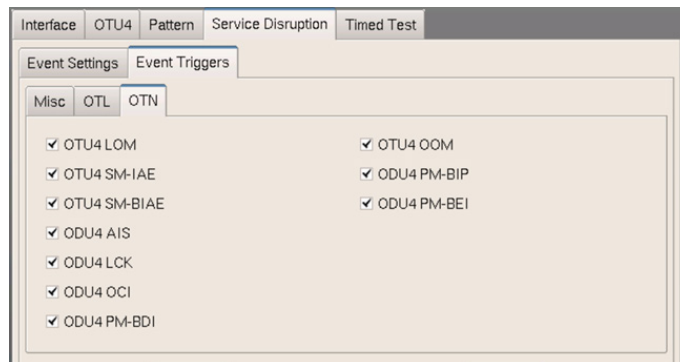

OTN service disruption

## Complete Fiber Channel Testing

T-BERD/MTS-5800-100G supports all fibre channel rates across dual ports. This includes 32GFC at 28.05Gbps. Support includes:

- Line rate traffic generation with buffer-to-buffer credit flow control
- RFC 2544 adapted for Fibre Channel
- Bit Error Rate, frame loss, and latency testing

## Part of the Leading T-BERD/MTS Test Portfolio



Common application base - same user interface + same results  
+ same methods and procedures

## StrataSync — Empower Your Assets

StrataSync is a hosted, cloud-enabled solution for managing assets, configurations, and test data on Viavi instruments. It ensures that all instrument software is current and the latest options are installed. StrataSync enables inventory management, test result consolidation, and performance data distribution anywhere with browser-based ease. It also improves technician and instrument efficiency. StrataSync manages and tracks test instruments, collects and analyzes results from the entire network, and helps train and inform the workforce



Contact Us **+1 844 GO VIAVI**  
(+1 844 468 4284)

To reach the VIAVI office nearest you,  
visit [viavisolutions.com/contacts](http://viavisolutions.com/contacts).

© 2017 VIAVI Solutions Inc.  
Product specifications and descriptions in this document are subject to change without notice.  
tberd-mts5800100g-pb-tfs-tm-ae  
30179914 900 0817