



Best Solution for Smartphone Manufacturing

Best Solution for Smartphone Manufacturing

Smartphone Evolution

Smartphones and tablets are showing remarkable success and the market continues to grow. In particular, smartphones are incorporating various new technologies, such as LTE, multiple antennas using MIMO, and connectivity wireless, like WLAN and *Bluetooth*.

Smartphone Production Challenges

Today's smartphones use 3G and LTE cellular wireless technologies with MIMO antennas for faster data transfer rates. With more RF components, smartphone manufacturers need more calibration and testing. As well as meeting the need for faster data communications, the fusion of cellular wireless and connectivity wireless technology is essential to smartphones. In implementing connectivity wireless, the module maker tests the connectivity wireless technology when the smartphone vendor purchases connectivity wireless modules for their smartphone. However, when implementing both cellular wireless and connectivity wireless in one chipset or when mounting a connectivity wireless chipset on-board (CoB: Chip on Board), the smartphone manufacturing vendor tests the connectivity wireless technology.

The many RF components and wireless technologies to test complicate the calibration of the test system by adding splitters and switches and control software. In addition, the many wireless technologies to test increase production costs through additional investment in test equipment at production ramp-up. In future smartphone manufacturing, a key issue in adapting to multiple wireless technologies is how to simplify test systems and cut production costs.

Test System Simplification

In terms of antennas today (smartphone RF components), smartphones incorporate cellular TRX, cellular RX diversity, WLAN/*Bluetooth*, GPS RX, and digital broadcast antennas. One piece of wireless test equipment with multiple connectors would be ideal in cutting production costs when testing these multiple RF paths. Moreover, from the viewpoint of test system simplification, one piece of wireless test equipment with internal devices such as splitters and switches and calibrated RF connection ports would be perfect.

The Universal Wireless Test Set MT8870A has four RF connection ports on a TRX test module. Test Port 1 and Test Port 2 are full duplex, while Test Port 3 and Test Port 4 are half duplex. The TRX test module has a Vector Signal Generator (VSG) and a Vector Signal Analyzer (VSA) connected to each RF port via a switch (Figure 1). All test ports are calibrated at the port edge.



Universal Wireless Test Set MT8870A

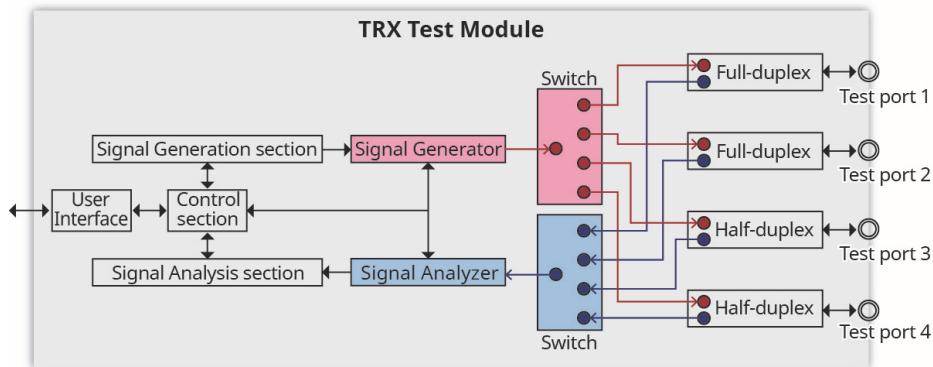

Figure 1 MT8870A TRX Test Module Block Diagram

Figure 2 shows a typical connection between the MT8870A and a smartphone. The example shows that a test system can be constructed with an external device. Since the test port is calibrated at the port edge, with no external device there is no complex calibration, which simplifies the test system calibration and control software.

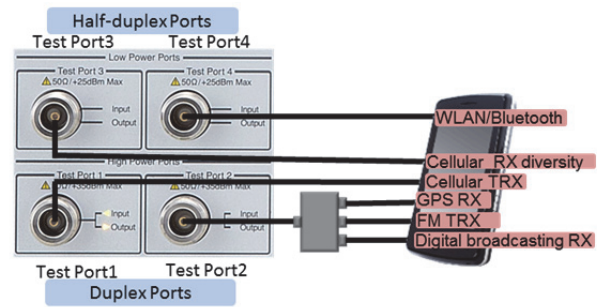

Figure 2 Connection between MT8870A and Smartphone

Cutting Future Production Costs

To meet future smartphone needs for faster data communications, the trend is towards installation of 802.11ac and LTE technologies. Supporting both 802.11ac and 802.11a/b/g/n requires an instrument with a measurement bandwidth of 160 MHz on the production line.

Since today's LTE will extend into the 4-GHz band with LTE-Advanced, any LTE test instrument must support future frequency bands.

The MT8870A has a wide measurement bandwidth of 160 MHz required for testing 802.11ac as well as a contiguous frequency range from 10 MHz to 6 GHz. In addition, since it runs measurement applications for both cellular and non-cellular wireless technologies including connectivity wireless, it is the ideal all-in-one measurement platform for cutting investment and production costs for both future cellular and non-cellular wireless technologies.

Conclusion

Today's smartphones are using MIMO antenna technology for faster data communications, and are also fusing cellular wireless with connectivity wireless technology. Smartphone manufacturers adapting to multiple wireless technologies face the twin challenges of how to simplify future test systems and cut costs.

The MT8870A with four RF ports on each module helps simplify test systems. Furthermore, with support for the 160-MHz wide bandwidth required for testing 802.11ac, a contiguous frequency range from 10 MHz to 6 GHz, and measurement applications for both cellular and non-cellular wireless, the MT8870A helps cut future investment and production costs.

• **United States**

Anritsu Company

1155 East Collins Blvd., Suite 100, Richardson,
TX 75081, U.S.A.
Toll Free: 1-800-267-4878
Phone: +1-972-644-1777
Fax: +1-972-671-1877

• **Canada**

Anritsu Electronics Ltd.

700 Silver Seven Road, Suite 120, Kanata,
Ontario K2V 1C3, Canada
Phone: +1-613-591-2003
Fax: +1-613-591-1006

• **Brazil**

Anritsu Eletrônica Ltda.

Praça Amadeu Amaral, 27 - 1 Andar
01327-010 - Bela Vista - São Paulo - SP - Brazil
Phone: +55-11-3283-2511
Fax: +55-11-3288-6940

• **Mexico**

Anritsu Company, S.A. de C.V.

Av. Ejército Nacional No. 579 Piso 9, Col. Granada
11520 México, D.F., México
Phone: +52-55-1101-2370
Fax: +52-55-5254-3147

• **United Kingdom**

Anritsu EMEA Ltd.

200 Capability Green, Luton, Bedfordshire, LU1 3LU, U.K.
Phone: +44-1582-433200
Fax: +44-1582-731303

• **France**

Anritsu S.A.

12 avenue du Québec, Bâtiment Iris 1- Silic 612,
91140 VILLEBON SUR YVETTE, France
Phone: +33-1-60-92-15-50
Fax: +33-1-64-46-10-65

• **Germany**

Anritsu GmbH

Nemetschek Haus, Konrad-Zuse-Platz 1
81829 München, Germany
Phone: +49-89-442308-0
Fax: +49-89-442308-55

• **Italy**

Anritsu S.r.l.

Via Elio Vittorini 129, 00144 Roma, Italy
Phone: +39-6-509-9711
Fax: +39-6-502-2425

• **Sweden**

Anritsu AB

Kistagången 20B, 164 40 KISTA, Sweden
Phone: +46-8-534-707-00
Fax: +46-8-534-707-30

• **Finland**

Anritsu AB

Teknobulevardi 3-5, FI-01530 VANTAA, Finland
Phone: +358-20-741-8100
Fax: +358-20-741-8111

• **Denmark**

Anritsu A/S

Kay Fiskers Plads 9, 2300 Copenhagen S, Denmark
Phone: +45-7211-2200
Fax: +45-7211-2210

• **Russia**

Anritsu EMEA Ltd.

Representation Office in Russia
Tverskaya str. 16/2, bld. 1, 7th floor.
Moscow, 125009, Russia
Phone: +7-495-363-1694
Fax: +7-495-935-8962

• **Spain**

Anritsu EMEA Ltd.

Representation Office in Spain
Edificio Cuzco IV, Po. de la Castellana, 141, Pta. 8
28046, Madrid, Spain
Phone: +34-915-726-761
Fax: +34-915-726-621

• **United Arab Emirates**

Anritsu EMEA Ltd.

Dubai Liaison Office

P O Box 500413 - Dubai Internet City
Al Thuraya Building, Tower 1, Suit 701, 7th Floor
Dubai, United Arab Emirates
Phone: +971-4-3670352
Fax: +971-4-3688460

• **India**

Anritsu India Private Limited

2nd & 3rd Floor, #837/1, Binnamangla 1st Stage,
Indiranagar, 100ft Road, Bangalore - 560038, India
Phone: +91-80-4058-1300
Fax: +91-80-4058-1301

• **Singapore**

Anritsu Pte. Ltd.

11 Chang Charn Road, #04-01, Shriro House
Singapore 159640
Phone: +65-6282-2400
Fax: +65-6282-2533

• **P.R. China (Shanghai)**

Anritsu (China) Co., Ltd.

Room 2701-2705, Tower A,
New Caohejing International Business Center
No. 391 Gui Ping Road Shanghai, 200233, P.R. China
Phone: +86-21-6237-0898
Fax: +86-21-6237-0899

• **P.R. China (Hong Kong)**

Anritsu Company Ltd.

Unit 1006-7, 10/F., Greenfield Tower, Concordia Plaza,
No. 1 Science Museum Road, Tsim Sha Tsui East,
Kowloon, Hong Kong, P.R. China
Phone: +852-2301-4980
Fax: +852-2301-3545

• **Japan**

Anritsu Corporation

8-5, Tamura-cho, Atsugi-shi, Kanagawa, 243-0016 Japan
Phone: +81-46-296-6509
Fax: +81-46-225-8359

• **Korea**

Anritsu Corporation, Ltd.

5FL, 235 Pangyo-yeok-ro, Bundang-gu, Seongnam-si,
Gyeonggi-do, 463-400 Korea
Phone: +82-31-696-7750
Fax: +82-31-696-7751

• **Australia**

Anritsu Pty. Ltd.

Unit 21/270 Ferntree Gully Road, Notting Hill,
Victoria 3168, Australia
Phone: +61-3-9558-8177
Fax: +61-3-9558-8255

• **Taiwan**

Anritsu Company Inc.

7F, No. 316, Sec. 1, NeiHu Rd., Taipei 114, Taiwan
Phone: +886-2-8751-1816
Fax: +886-2-8751-1817