



# Universal Wireless Test Set MT8870A

# Contents

- Anritsu Mobile Communications Equipment Test Solution
- MT8870A Product Introduction
  - Test set for Manufacturing
  - MT8870A/MU88700xA Features
- Application Examples
  - Smartphone Manufacturing
  - Connectivity / IoT Module Manufacturing

# MT8870A Universal Wireless Test Set Introduction

- Anritsu Mobile Communications Equipment Test Solution
- MT8870A Product Introduction
  - Test set for Manufacturing
  - MT8870A/MU88700xA Features
- Application Examples
  - Smartphone Manufacturing
  - Connectivity / IoT Module Manufacturing

# Evolving Wireless Devices

- Today's smartphones and tablets use a variety of wireless standards. Wireless communications are continuing to evolve to meet users' needs and wireless applications are becoming part of everyday life.
- R&D and manufacturing of mobile terminals and communications modules require support for assorted wireless tests to assure continuing product quality.
- Manufacturing of multi-wireless-standard mobiles and modules requires configuration of an efficient and low-cost test environment.

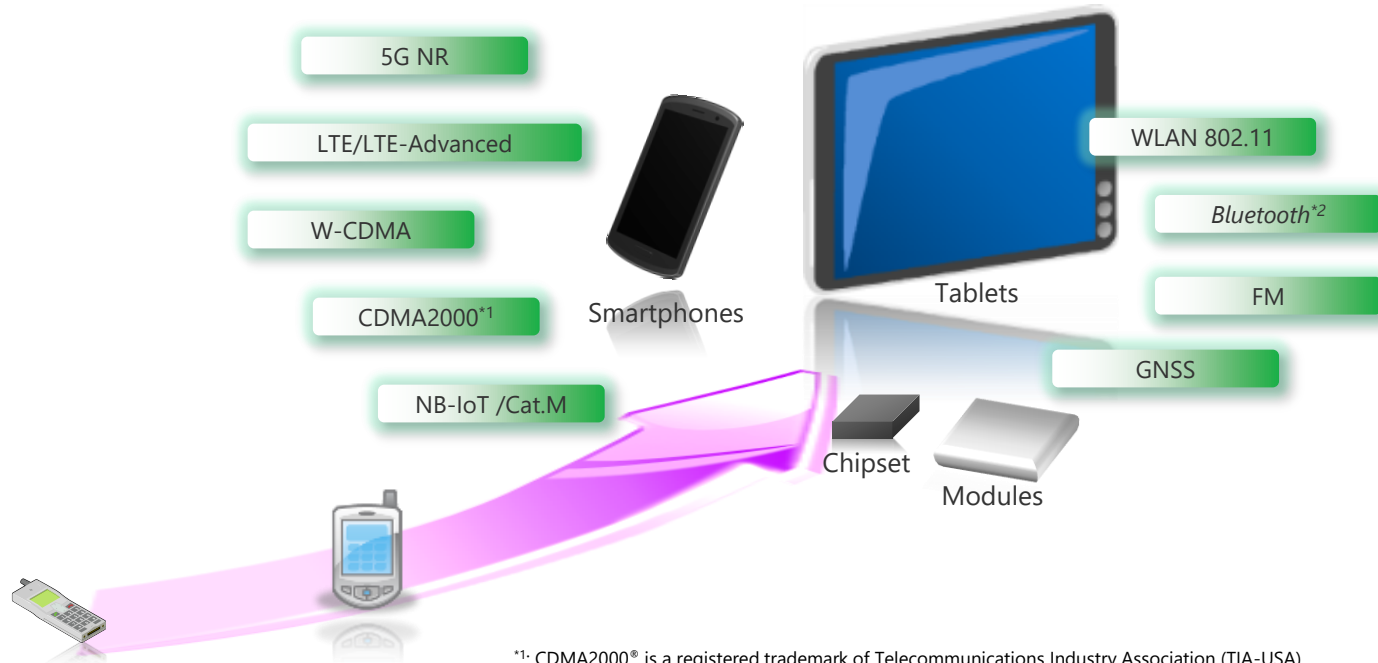

\*1: CDMA2000® is a registered trademark of Telecommunications Industry Association (TIA-USA).

\*2: The Bluetooth® word mark and logos are owned by the Bluetooth SIG, Inc. and any use of such marks by Anritsu is under license

# Solutions from R&D to Manufacturing



- Smartphone
- Tablet
- Cellular Module

5G NR



LTE/LTE-Advanced

NB-IoT/Cat-M

W-CDMA

GSM

CDMA2000



MS269xA/MS2850A  
Signal Analyzer



MT8000A  
Radio Communication Test Station



MT8870A  
Universal Wireless Test Set

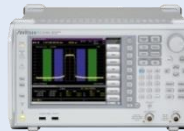

MS269xA/MS2850A  
Signal Analyzer



MD8430A  
Signaling Tester



MD8475A/B  
Signaling Tester



MG3710A/MG3740A  
Vector Signal Generator



MT8821C  
Radio Communication Analyzer



MT8820C  
Radio Communication Analyzer

- Connectivity Module
- Wearable / IoT devices
- AP / STB



WLAN 802.11

Bluetooth

ZigBee/Z-Wave



MS269xA/MS2850A  
Signal Analyzer



MG3710A/MG3740A  
Vector Signal Generator



MT8870A  
Universal Wireless Test Set



MT8852B  
Bluetooth Test Set



MT8862A  
Wireless Connectivity Test Set

# MT8870A Universal Wireless Test Set Introduction

- Anritsu Mobile Communications Equipment Test Solution
- MT8870A Product Introduction
  - Test set for Manufacturing
  - MT8870A/MU88700xA Features
- Application Examples
  - Smartphone Manufacturing
  - Connectivity / IoT Module Manufacturing

# Test Set for Manufacturing



## Cut Costs

- All-in-one platform accommodating four test modules
- Flexible modular design cuts cost
- Robust platform for production lines

## Fast Measurement

- High-speed CPU and large memory in each installed module
- Supports latest test methodologies

## Expandability/Potential

- All-in-one unit supporting assorted wireless standards tests
- Expandable by software
- Standards future-proof wideband hardware design

# Supports Up to Four Modules



- Supports Four Modules
  - The MT8870A Universal Wireless Test Set supports up to four test modules in one main frame chassis.
- Shared Hardware Resources Cut Costs
  - With four TRX modules installed in one MT8870A main frame, the shared power supply, chassis, internal communications bus, remote controller, reference frequency oscillator, software license, etc., cut capital costs.
  - Installing four test modules cuts cost per unit.

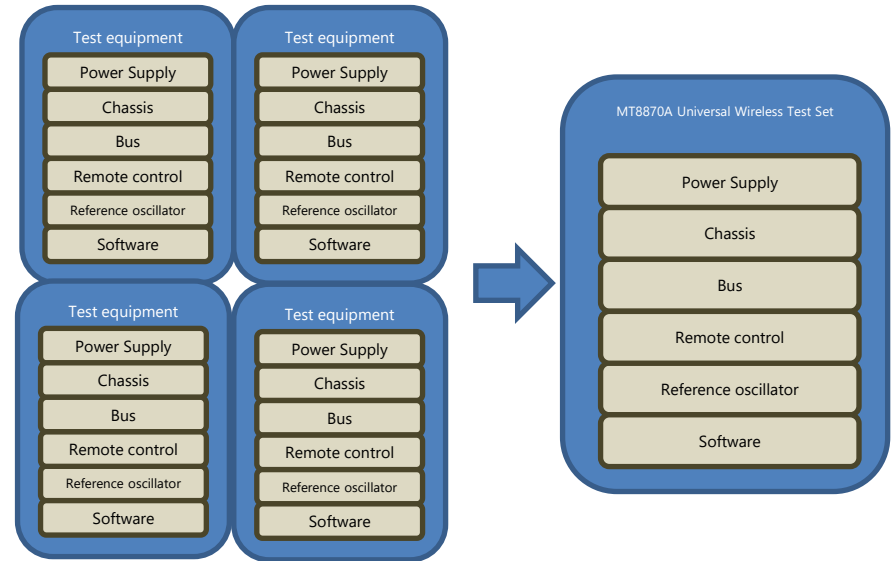
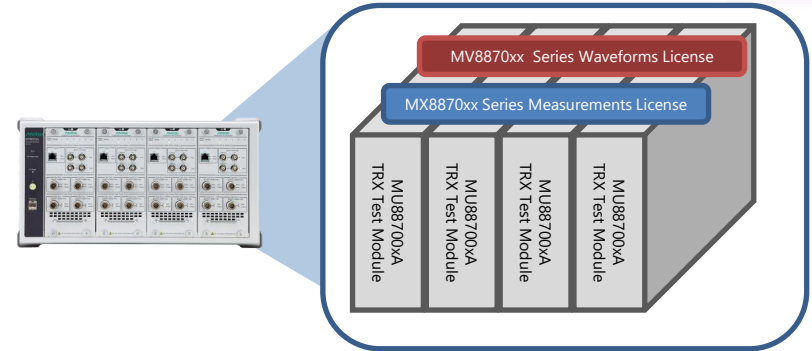



# Modular Design Cuts Costs

Cuts Costs

- Supports Flexible Manufacturing Line Changes
  - The MU88700xA TRX Test Module easily supports production line configuration and model changes, eliminating backup instruments and cutting capital investment.
- Cuts Line Downtime
  - Easy module swap-out cuts line downtime.
  - No wasted time disconnecting remote control cables, power cables and coaxial cables on back panel so changeovers only take minutes.

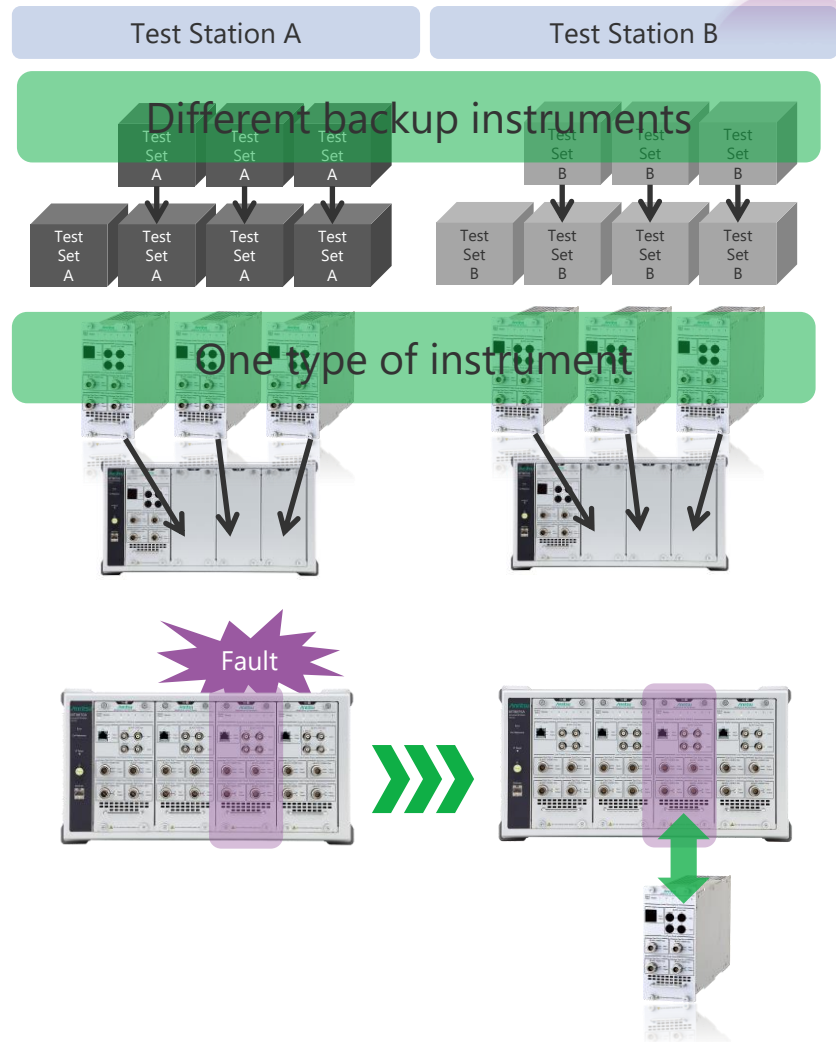

# Production Line Aware Platform



- Slimmed Down Auto-Measurements
  - Inspection production lines use auto-measurement programs to capture numeric measurement results from test set for pass/fail evaluation.
  - Eliminating line displays and instrument front-panel buttons while supporting remote control via Ethernet or GPIB cuts instrument costs, helping reduce device production costs.
  
- 50% to 75% Smaller Footprint
  - Instead of four separate test stations each requiring setup, the all-in-one, high-performance MT8870A main frame with up to four installed test modules saves both production line space and setup time.

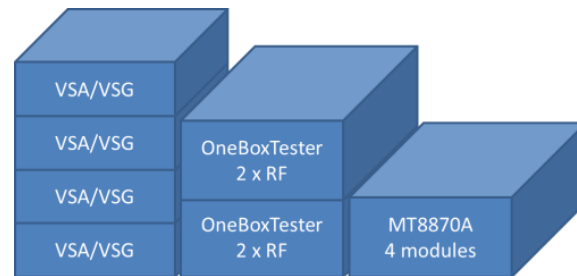

Compared to Anritsu products	VSA/VSG	All-in-one Tester (Parallel Phone)
MT8870A 4 Module Configuration	75% smaller	50% smaller

# Shorter Measurement Times



- Fast Measurements Independent of External PC
  - The Dual Core CPU, DDR3 memory and fast PCIe bus in each MU88700xA TRX Test module assure fast measurements independent of the external PC.
- Signal Generator and Signal Analyzer in Each Test Module
  - Each of the four test modules installed in the main frame has an independently operated signal generator and signal analyzer supporting separate parallel testing of up to four mobiles.
- Large Memory
  - 2 GB digitizer memory for TX tests supports one-run, long-term capture.
  - RX test waveforms can be preloaded into 4 GB ARB memory, cutting reload times when switching wireless standards.

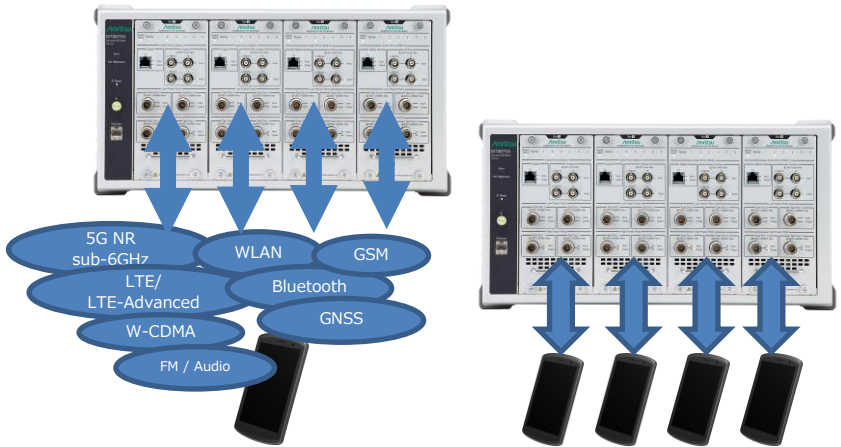
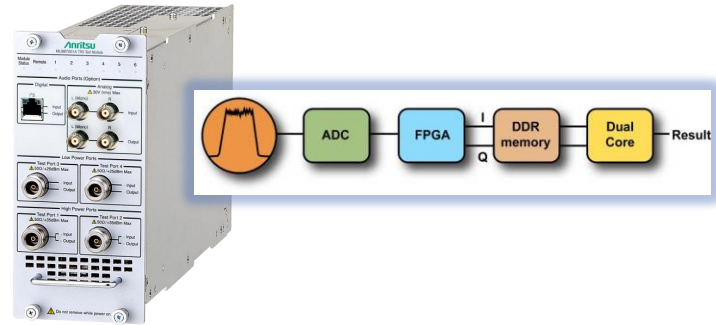

# Supports Latest Manufacturing Technologies

Fast Measurements

- Signaling measurements using wireless communications to set devices and test set have long test times due to the time taken to establish wireless communications. The supported non-signaling method cuts test times by omitting wireless communications and controlling directly from an external PC. To eliminate communications with the external PC, the sequence measurement (List Mode) function performing measurement between the device and instrument according to a known measurement sequence, is also supported for future implementations.

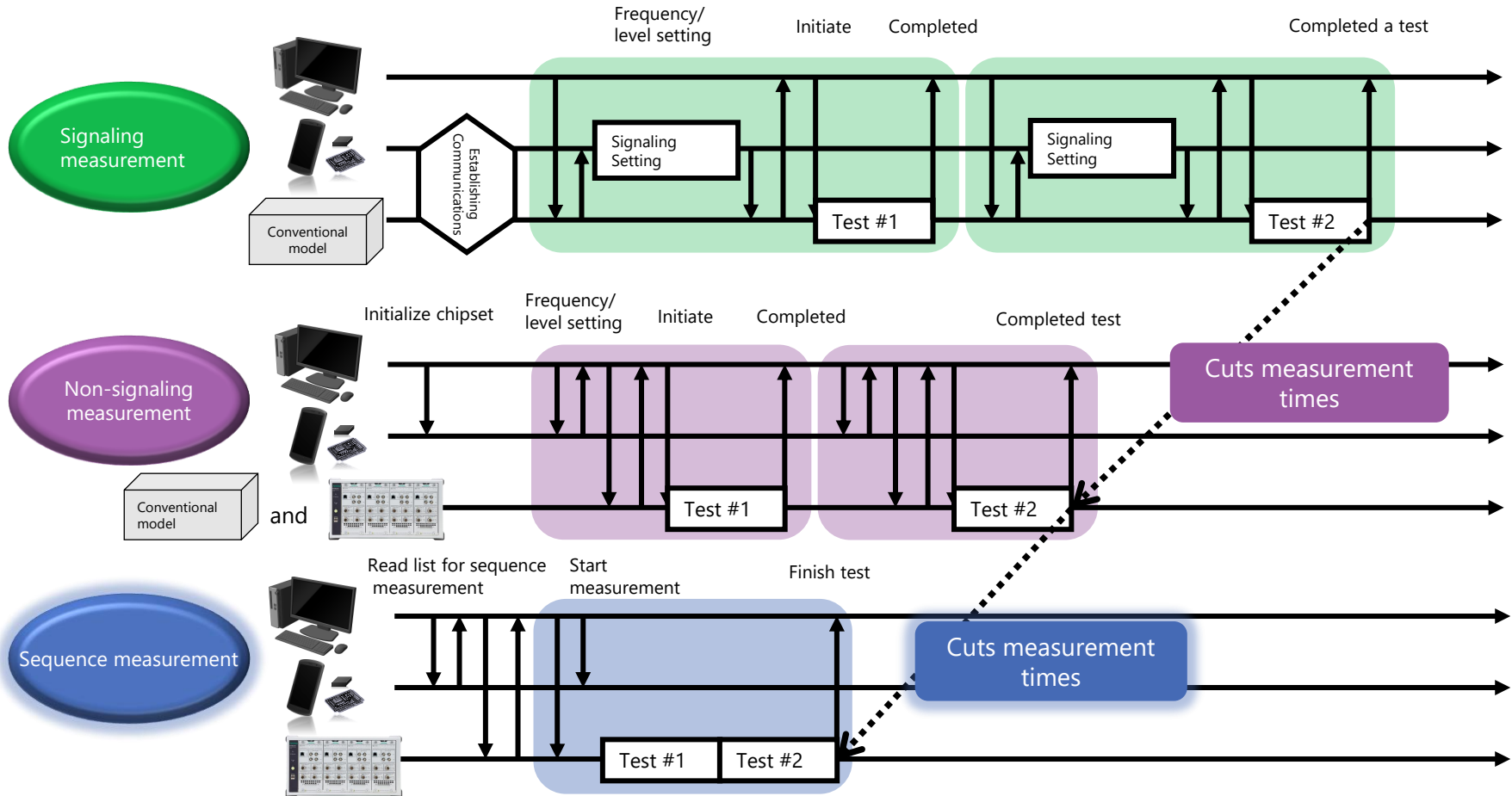

# Expandable Platform

Expand Ability

- Support Assorted Wireless Standards

- TRX measurements of all key wireless standards are supporting by installing the TRX test modules with optional measurement software packages and waveform files in the MT8870A Universal Wireless Test Set.

- Easy Software Expansion

- New standards are easily supported by adding software licenses.
- Advanced MU88700xA hardware offers long term cost reduction with future proof platform such as 11ax and 5G NR sub-6GHz support without hardware upgrade.

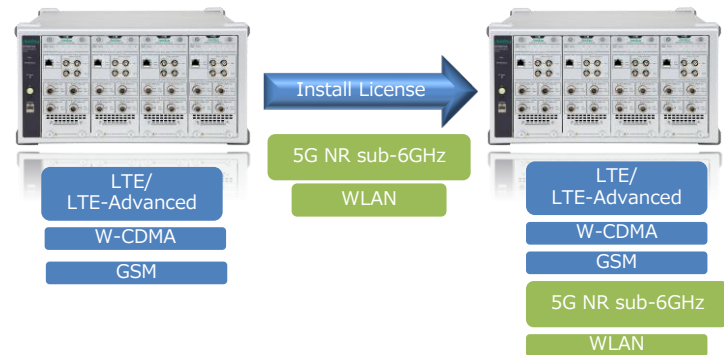
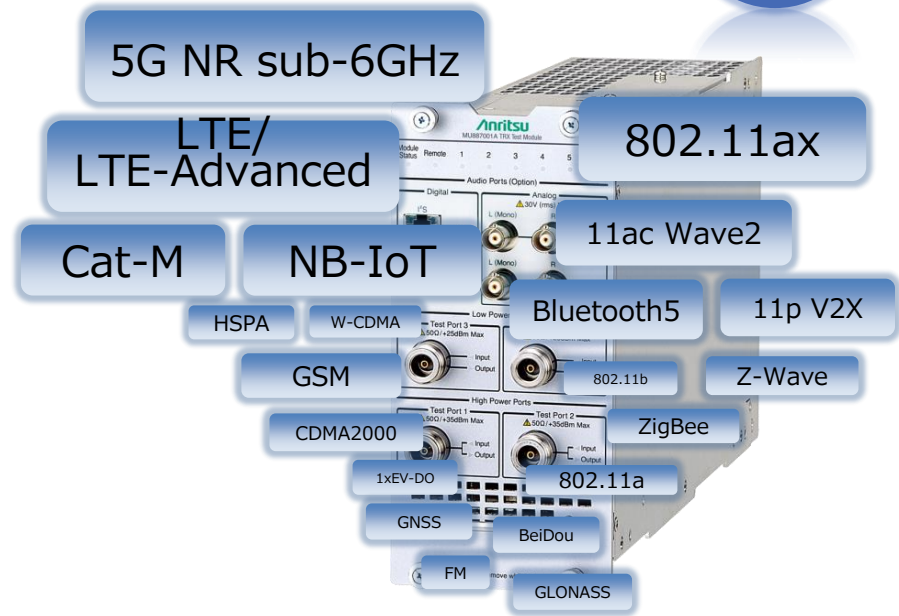

# Four Ports on Each TRX Test Module



	MU887000A	MU887001A
Connector Types	Test port 1 and 2 <ul style="list-style-type: none"> <li>• Full-duplex</li> <li>• Test port for cellular applications supporting simultaneous TRX.</li> </ul> Test port 3 and 4 <ul style="list-style-type: none"> <li>• Half-duplex</li> <li>• Supports either TX or RX with better input sensitivity than full duplex.</li> <li>• Useful for WLAN antenna coupling measurements.</li> </ul>	Test port 1 to 4 <ul style="list-style-type: none"> <li>• Full-duplex</li> <li>• Test port for cellular applications supporting simultaneous TRX.</li> </ul>
Output Level Setting Range	Test port 1 and 2 <ul style="list-style-type: none"> <li>-130 to -10 dBm (<math>\leq 3.8</math> GHz)</li> <li>-130 to -18 dBm (<math>&gt; 3.8</math> GHz)</li> </ul> Test port 3 and 4 <ul style="list-style-type: none"> <li>-120 to 0 dBm (<math>\leq 3.8</math> GHz)</li> <li>-120 to -8 dBm (<math>&gt; 3.8</math> GHz)</li> </ul>	Test port 1 to 4 <ul style="list-style-type: none"> <li>-130 to -10 dBm (<math>\leq 3.8</math> GHz)</li> <li>-130 to -18 dBm (<math>&gt; 3.8</math> GHz)</li> </ul>
Input Level Setting Range	Test port 1 and 2 <ul style="list-style-type: none"> <li>-65 to +35 dBm (CW, <math>350 \text{ MHz} \leq f \leq 6.0 \text{ GHz}</math>)</li> </ul> Test port 3 and 4 <ul style="list-style-type: none"> <li>-65 to +25 dBm (CW, <math>350 \text{ MHz} \leq f \leq 6.0 \text{ GHz}</math>)</li> </ul>	Test port 1 to 2 <ul style="list-style-type: none"> <li>-65 to +35 dBm (CW, <math>350 \text{ MHz} \leq f \leq 6.0 \text{ GHz}</math>)</li> </ul>

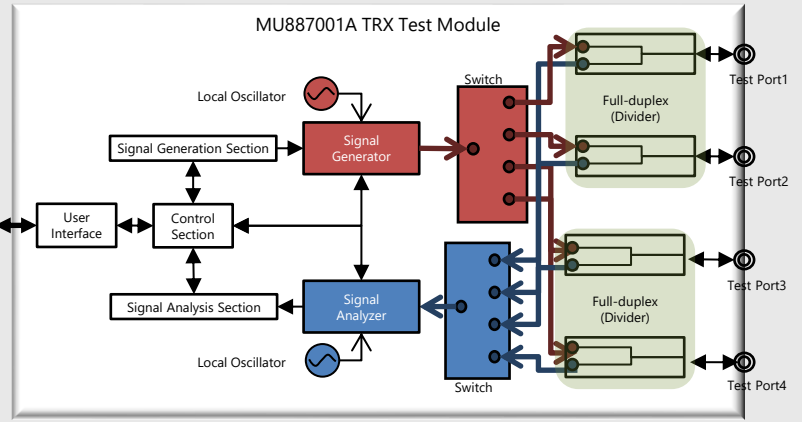
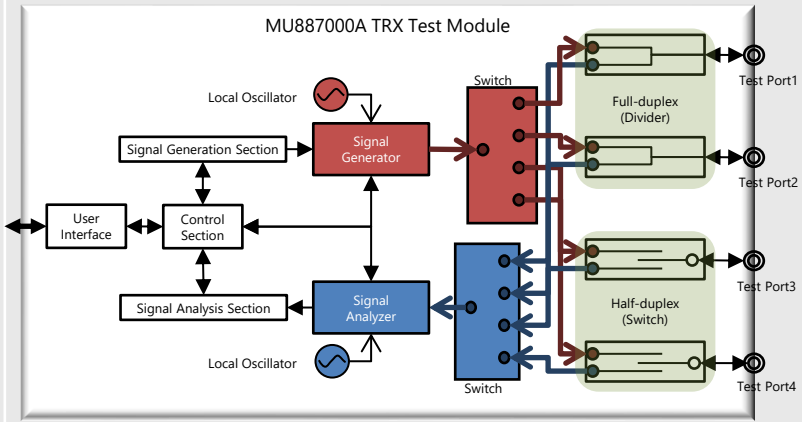

# High-Performance/Wideband Platform

Expand  
Ability

- 160 MHz Bandwidth as Standard
  - The latest 802.11ac Wave2, 5G NR sub-6GHz and LTE-Advanced bandwidth standards are supported as standard. Usually, upgrading bandwidth requires extra costs for changing instruments, adding options, etc., but since the MU88700xA has a 160 MHz wide bandwidth as standard, these extra costs are unnecessary.
- 10 MHz to 6 GHz Wide Frequency Range
  - To provide future-proof frequency-band extendibility, the frequency band covers a wide range from 10 MHz at the lower end to 6 GHz (option) at the upper end.
  - The wideband (10 MHz to 6 GHz) signal generator and signal analyzer support easy and smooth extendibility for new wireless standards, unlike dedicated test set supporting only specific frequencies.



# Built-in Audio Analyzer / Generator

Expanda  
bility

Cuts  
Costs

- MU88700xA-002 Audio Measurement Hardware
  - By using FM TRX measurement capability, the built-in audio analyzer / generator is available to perform audio signal measurements.
  - Frequency Range : 20 Hz to 20 kHz
  - Audio Input / Output Connectors
    - Analog Audio Interface : BNC Connectors (L / R)
    - Digital Audio Interface (I<sup>2</sup>S) : RJ45 Connector
  - TX Testing : Audio Level, Frequency, Distortion etc



FM Receiver Test

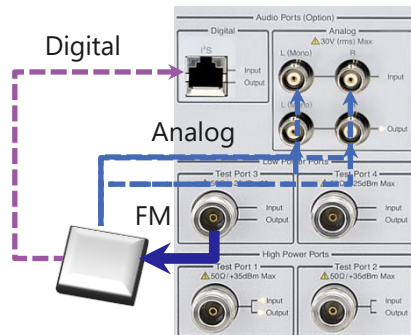

FM Transmitter Test

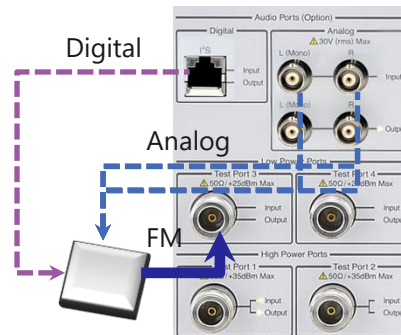



# Key Facts

Model/Name	Parameters	Specifications
MT8870A Universal Wireless Test Set	Number of Slots	4
	Remote Control	Individual control of each module Ethernet (standard) or GPIB (option)
	User Interface	PC Applications (CombiTest / Utility Tool / CombiView)
	Size and Mass	426 (W) × 221.5 (H) × 498 (D) mm (excluding protrusions), ≤30 kg (4 modules)
MU88700xA TRX Test Module	Supported Systems	LTE/LTE-Advanced FDD, LTE/LTE-Advanced TDD, W-CDMA (HSPA), GSM (GSM/GPRS/EGPRS), CDMA2000, 1xEV-DO, NB-IoT, Category M(Cat-M), WLAN(802.11a/b/g/n/p(V2x)/ac/ax), Bluetooth BR/EDR/BLE, FM TRX (Audio), GPS, GLONASS, BeiDou, Digital Broadcast
	Frequency Range	10 MHz to 6 GHz (standard: 3.8 GHz*) *Extend to 6 GHz as option
	Bandwidth	VSA: 160 MHz max. (200 Msa/s max.) VSG: 160 MHz max. (20 k to 200 Msa/s)
	RF Test Ports	4
	ARB Memory	4 GB (1 Gsa)
	Digitizer Memory	2 GB (256 Msa)
	Measurement Methods	Non-signaling (Direct Mode)

See MT8870A product brochure for more details

# PC Applications



- CombiView

- CombiView is PC application software with a GUI for displaying detailed information, such as the test device TX power and status, modulation constellation, etc., on a PC for use at R&D, on production lines, and at troubleshooting.

- Graphical display of TX measurement results using Windows interface
- Remote control of MT8870A (MU88700xA) via Ethernet and GPIB (option)
- Setting of MT8870A (MU88700xA)
- Signal generator interface for RX tests

- MT8870A Utility Tool (MX887900A)

- The MX887900A is a utility tool software package for installing in a PC. It can be used to detect the networked MT8870A via Ethernet or GPIB (option) and for block updates such as internal firmware.

- Displays details of MT8870A and MU88700xA TRX Test Module(s) detected on network
- MU88700xA TRX Test Module firmware upgrade
- Transfer waveform file
- License registration

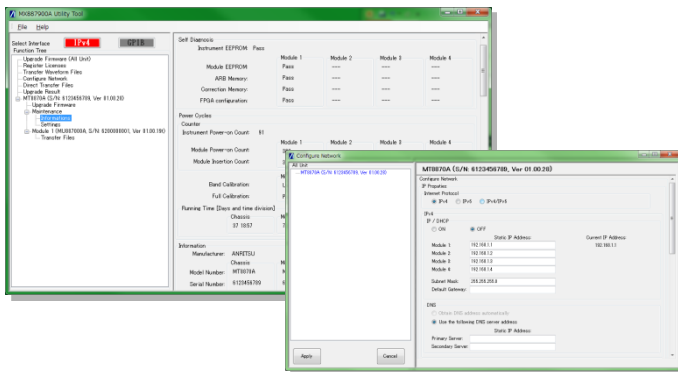

# MT8870A Summary

Low-cost instrument for production lines

- Low cost due to resource sharing by four modules in one main frame
- Shared modules cut equipment investment

Cuts measurements times

- Supports fast calibration and fast verification sequence measurement
- Each module has Dual Core CPU and high-speed bus
- 4 slot module configuration supports four parallel measurements

Supports mobile communications (cellular) and short range wireless

- Supports assorted short range wireless standards, such as WLAN, Bluetooth, FM/Audio, GNSS, as well as cellular including 5G NR sub-6GHz

Expandability

- Individually controlled modules
- Shared platform supports expansion by adding software

Future proof

- Supports frequencies and bandwidths required for 5G NR sub-6GHz, LTE-Advanced and 11ax
- Modular design offers low-cost expandability

# MT8870A Universal Wireless Test Set Introduction

- Anritsu Mobile Communications Equipment Test Solution
- MT8870A Product Introduction
  - Test set for Manufacturing
  - MT8870A/MU88700xA Features
- Application Examples
  - Smartphone Manufacturing
  - Connectivity / IoT Module Manufacturing

# Smartphone Manufacturing

The MT8870A supports smartphone manufacturing flexibility.



# All-in-one Unit Supports Cellular and Connectivity

- The MU88700xA TRX Test Module with four RF test ports supports connection with mobile device, that has Cellular, Connectivity and GNSS, without external devices.
- Wide frequency range from 10 MHz to 6 GHz (option) supporting multiple wireless technologies in one unit.
- With Installing option of audio measurement hardware into the MU88700xA, it is not required to prepare external audio instrument.

Configuration of Traditional Test System

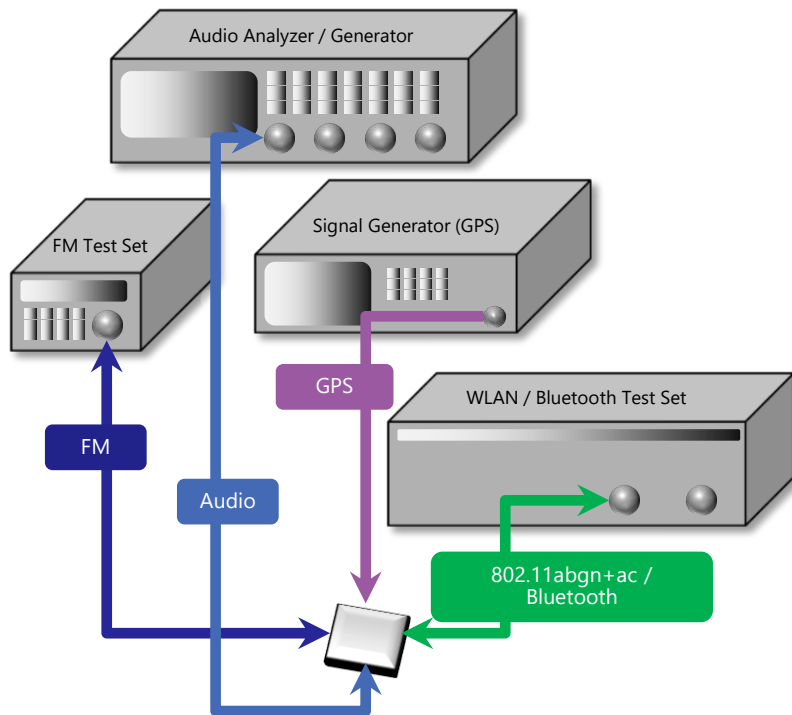

Configuration of MU88700xA TRX Test Module

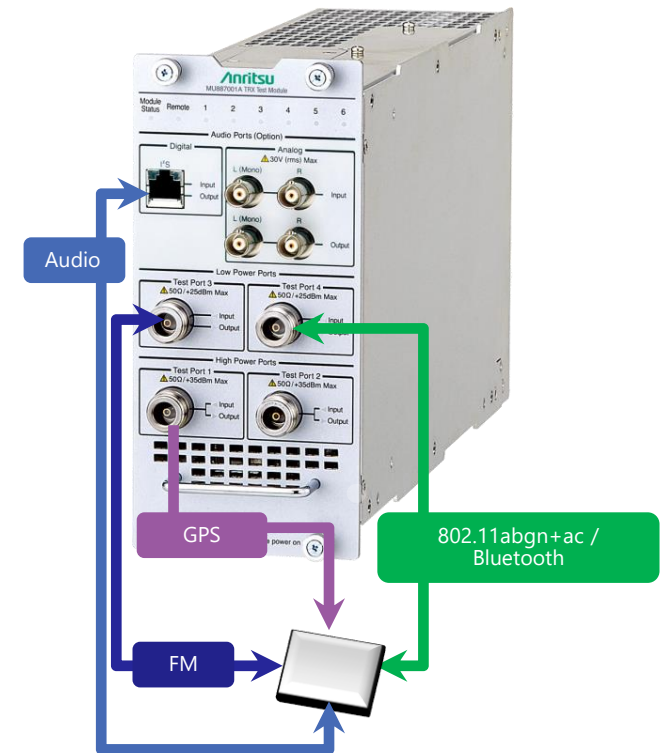

# Improve Manufacturing Throughput by Cutting Setup

- Setup time is a large burden on manufacturing efficiency. Since one MT8870A main frame supports every test, wasteful setup time is eliminated.

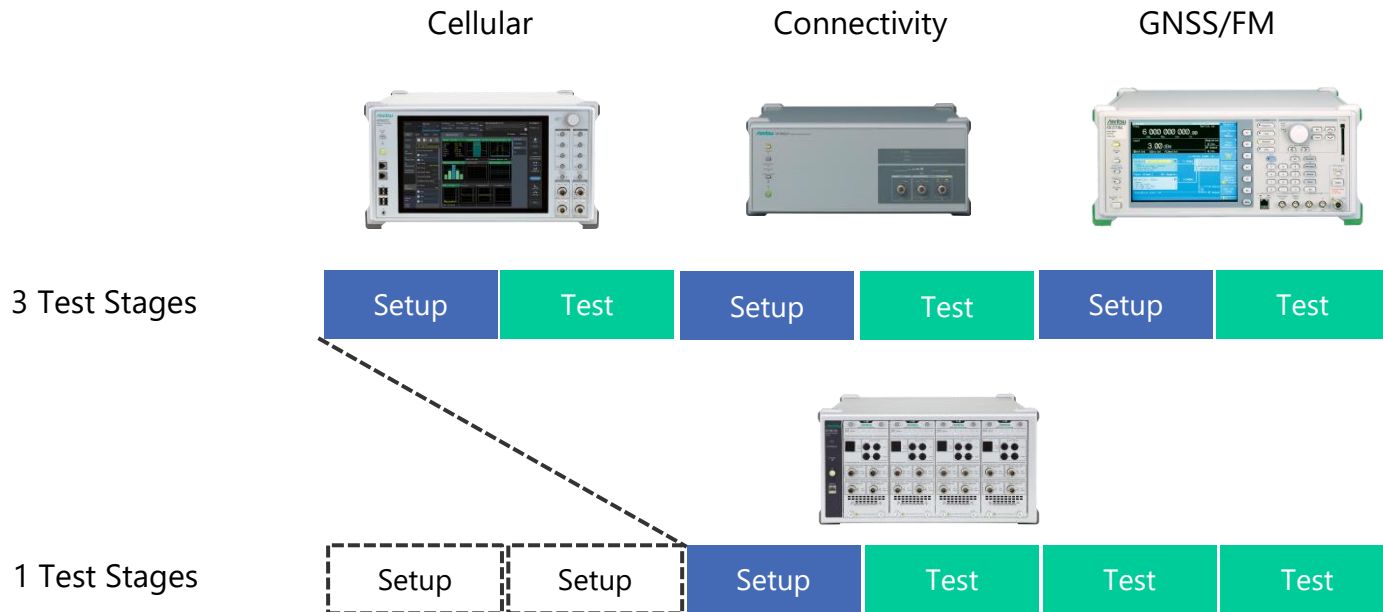

Reducing test stage cuts setup times and improves throughput in 22%.  
(Setup Time: 40 s; Test Time: 80 s for all test stages)

# FM Transceiver measurement with built-in audio feature

- MT8870A with MU88700xA is available to support TRX testing of FM transceiver. If MU88700xA added an option of audio measurement hardware, it is also available to perform audio testing.
- MU88700xA is able to support audio analyzer and audio generator internally. Therefore, MT8870A does not require an external audio analyzer/generator additionally, and it is able to propose to cut costs and reduce footprint of instruments for FM / audio testing.

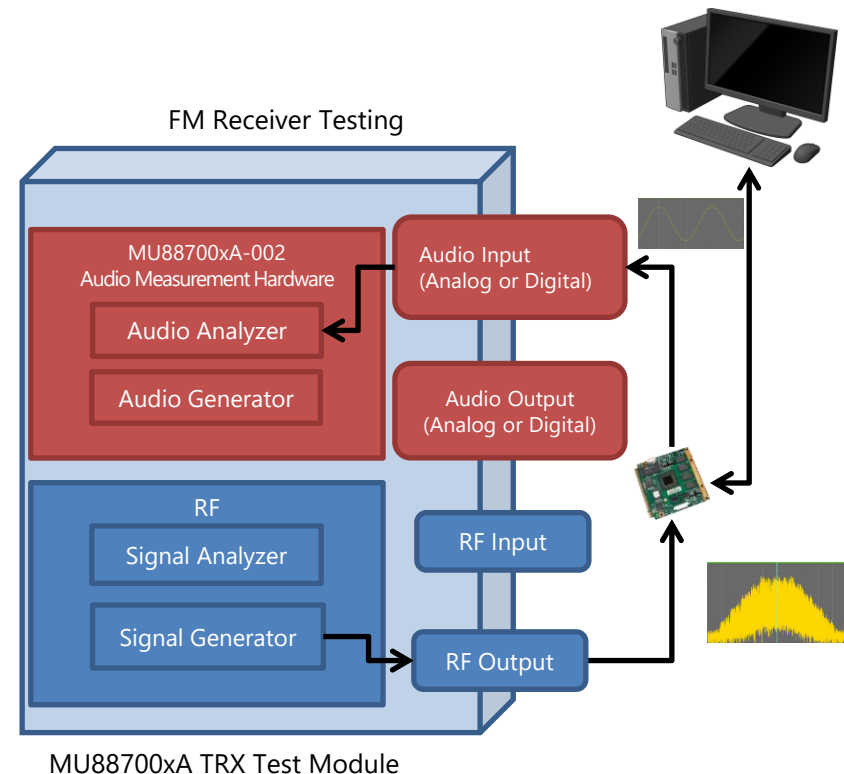
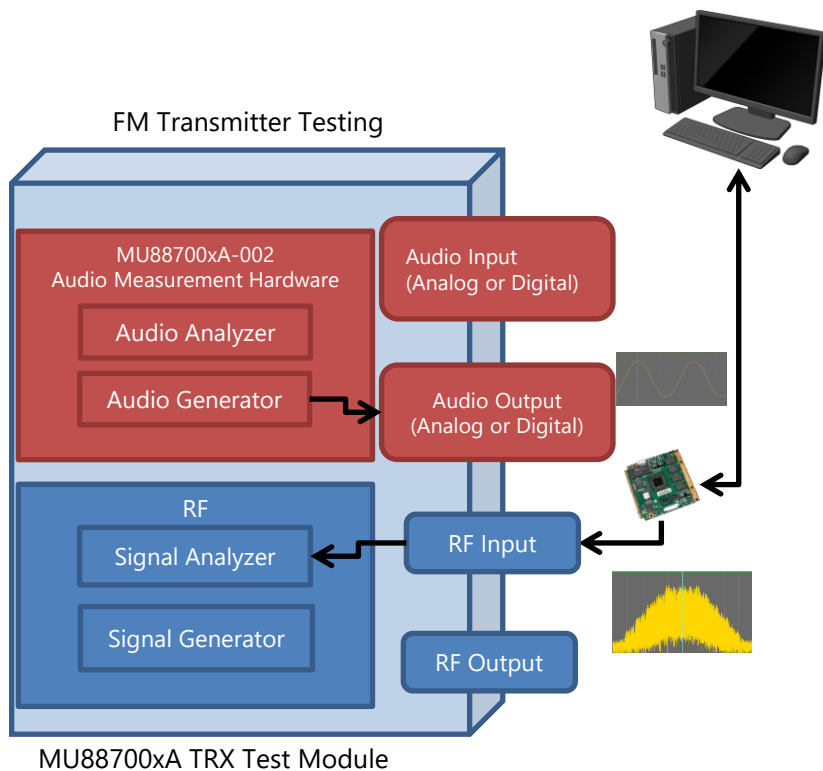



# Connectivity/ IoT Module Manufacturing



The MT8870A cuts communication module manufacturing costs.

# Advantages for 802.11ac Manufacturing

- Testing 802.11ac does not require extra costs because the MU88700xA TRX Test Module supports the 160 MHz bandwidth as standard.

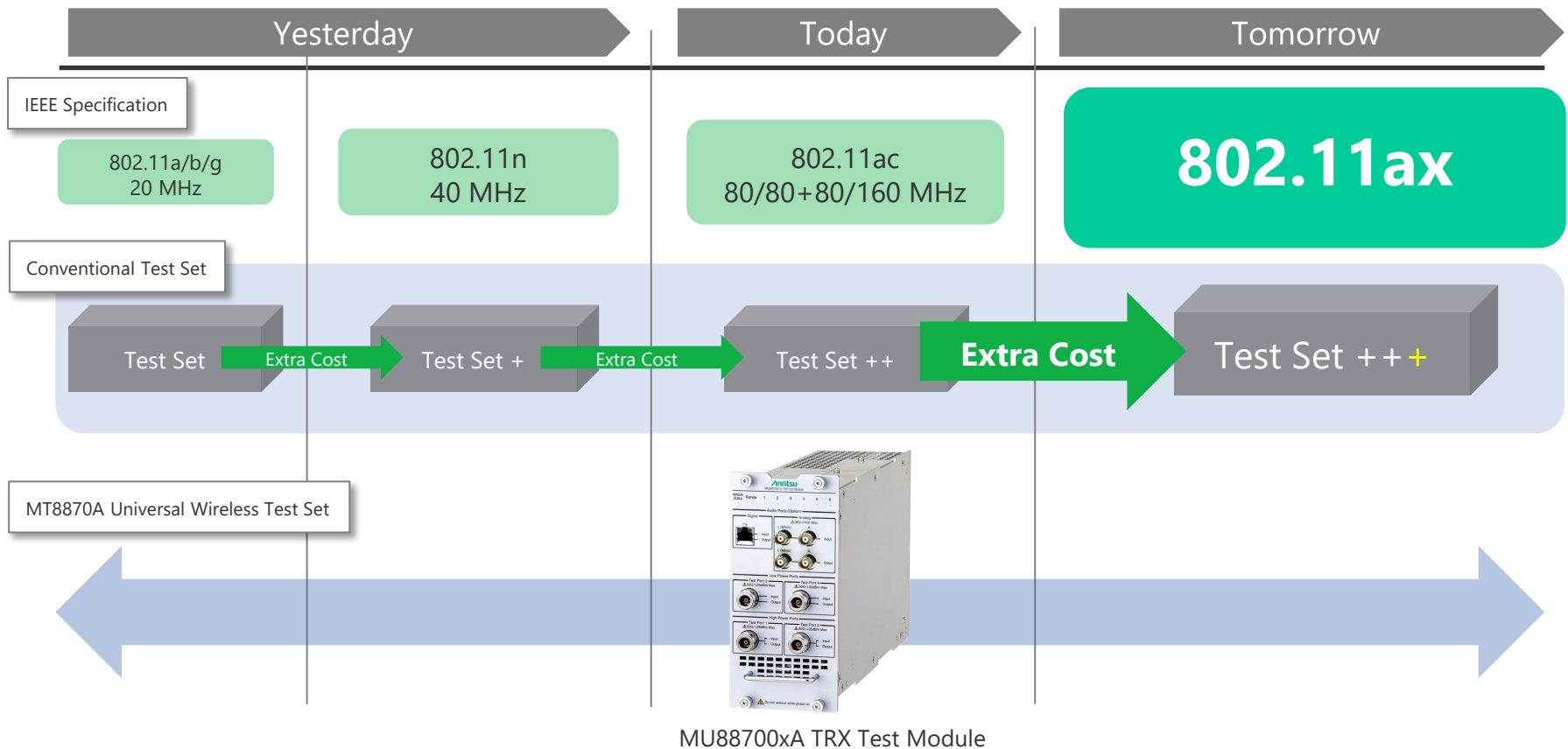

# 16 Simultaneous Connections

- Versatile development flexibility with four devices connected to each of four modules
- Up to 16 test fixtures can be connected to a single MT8870A test set when fully loaded with 4 MU88700xA TRX modules. As each module is completely independent, this facilitates the testing of four devices in parallel. This test system approach eliminates the need for external combiners in a test system which have poor isolation, and also reduces the required test fixture path calibration.

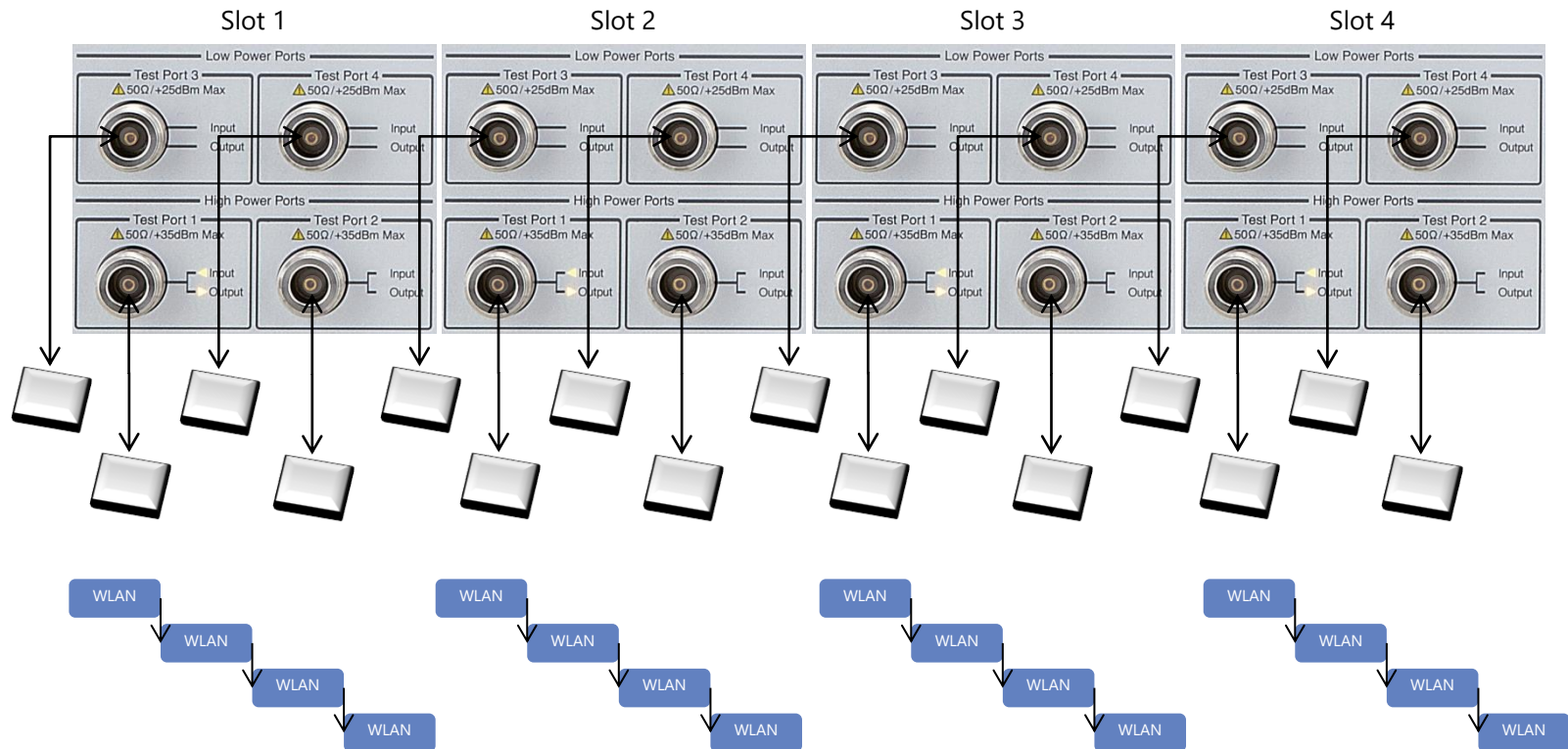

# Improves System Efficiency

- Versatile development flexibility with four devices connected to each of four modules.
- Connecting two DUT devices each with two RF terminals to each of the four TRX test modules supports simultaneous connection of 8 test devices, simplifying system setup for 802.11 diversity antenna tests.

